

# Signalink™ USB

With built-in Sound Card



- FCC Class B Certified
- Built-in Low-noise Sound Card
- Simple Installation and Setup
- Complete Radio Isolation
- USB Port Powered
- Works with ALL Radios
- Uses Mic, Data, or Accy Port
- Supports All Sound Card Digital and Voice Modes

## *Operate All Sound Card Digital & Voice Modes!*

[Click here to read the April 2008 QST Magazine review of the Signalink USB!](#)

Once again Tigertronics sets the pace in digital operating! The new Signalink™ USB combines the legendary performance of our SL-1+ with a state of the art "built-in" low-noise USB Sound Card. This ground breaking innovation delivers optimum performance while eliminating the need to attach to your computer's existing sound card. Convenient front panel controls and simplified installation make this one of the most user-friendly interfaces on the market, continuing to show that the Tigertronics Signalink is truly the "Ultimate interface"!

ALL sound card Digital and voice modes are supported by the Signalink™ USB. This includes traditional modes such as RTTY, SSTV and CW (to name a few), as well as today's hottest new modes like PSK31, MT-63 and EchoLink®. Performance on all modes has been optimized by the use of special low-noise parts and careful design techniques, while ease of operation is provided by front panel controls that let you adjust your Transmit Audio, Receive Audio and Transmit delay "on the fly".

The Signalink™ USB works with ALL radios and can be attached to the Mic jack, Data Port or Accessory Port. Most customers will want to attach the unit to the back of the radio (Data or Accy Port), as this will allow the microphone to stay plugged in. A wide selection of **Fully assembled radio cables** are available for all common base and mobile radios. A special un-terminated radio cable is available for radios that use a non-standard connector, or for use with hand-held radios (HTs).

The Signalink™ USB comes fully assembled and tested. As with all Tigertronics products, it employs "State Of The Art" **Surface Mount construction**, and every unit is Robotically Assembled in our own modern factory to ensure maximum performance and reliability. All components are of the highest quality, and every unit undergoes the same stringent quality control and inspection standards that you have grown to expect from Tigertronics! We invite you to compare every aspect of the Signalink™ USB to other sound card interface products. We think you will agree that we have offered a level of innovation, quality, and value that cannot be beat!

## Features:

- **FCC Certified** - Unlike virtually all of our competitors, the Signalink USB has been tested and found to comply with the limits for a Class B digital device, pursuant to Part 15 of the FCC Rules.
- **Built-in Low Noise Sound Card** - This provides optimum performance and frees your computer's existing sound card for other uses. It also greatly simplifies installation and operation, by reducing the number of cable connections, and by providing consistent performance that is independent of the computer's sound card.
- **Simple Installation** - The Signalink USB has only one USB connection to the computer, and in most cases, only one connection to the radio\*. There are no audio cables to get mixed-up!
- **Easy Setup and Operation** - The Signalink USB's built-in sound card provides consistent audio levels and performance that is completely independent of the computer's sound card. This lets us streamline our Audio Level Setting procedure like never before. Simply set the software "Transmit" audio controls as described in the Signalink manual, and then adjust the Signalink's front panel "TX" control for the desired RF power level. Setting of the RX Level is even easier, as this is done completely by the Signalink front panel "RX" control. There are no software "Recording" controls to adjust!
- **Convenient Front Panel Controls** - You can now easily adjust your TX Audio, RX Audio and Transmit Delay without having to open the Signalink case. This lets you optimize your Transmit Audio (RF Power), Receive Audio level ("waterfall drive"), and Transmit "Hang Time" delay "on the fly"!
- **Works with ALL Radio Mic, Data, and Accessory Ports** - The Signalink USB works with ALL radios, and can be attached to your radios Mic, Data, or Accessory port. This allows most users to attach the Signalink to the back of the radio (Data or Accessory Port) and leave the microphone plugged in!
- **Supports All Sound Card Digital & Voice Modes** - The Signalink USB supports ALL Digital and Voice modes that are available for sound card interfaces. This includes ALL traditional modes such as CW, RTTY, AMTOR, and SSTV (to name a few), and ALL new modes such as PSK-31, MT-63, and EchoLink®. All standard sound card communications programs will work with the Signalink USB.
- **Complete Isolation** - Unlike some interfaces on the market, ALL Signalink models COMPLETELY isolate your computer from your radio. This eliminates troublesome ground loops and prevents hum and noise from degrading the signals. The Signalink USB provides isolation through the use of audio transformers and a relay-based PTT keying circuit.
- **Transmit Audio / "Side Tone" Output** - A rear panel "Monitor" jack can be used with headphones or powered (amplified) speakers to monitor your Transmit Audio, or Side Tone during CW operation.
- **External Speaker Support** - If your installation requires that you attach the Signalink to your radio's External Speaker jack, then you can plug an external speaker or headphones into the

Signalink's rear panel "Aux" jack and continue to hear your RX Audio.

- **No External Power Required** - The Signalink USB is always powered by the computer's USB port, so external power is NEVER required..

**\*NOTE:** Some radio's do not have the "RX Audio" signal on the Mic connector and will require a mono cable to be installed between the Signalink USB and the radio. This is never an issue if you attach the Signalink to your radio's Data or Accessory Port.

---

## What's Included?

Every Signalink USB is supplied with the following items:

- **Fully Assembled Detachable Radio Cable** - The Signalink [part number](#) determines which radio cable is supplied with the unit (**please specify when ordering**). Cables are available for ALL radios that use a 4-pin round, 8-pin round, RJ-11, and RJ-45 mic connector. Cables are also available for ALL radios that have a Data or Accessory Port that uses a 5-pin DIN, 8-pin DIN, 13-pin DIN\*\*, or 6-pin mini-DIN connector. An un-terminated cable is available for radios that uses a different type of connector, or for building a cable for an HT.
- **USB Cable** - This cable connects the Signalink USB to your computer. It is six feet in length.
- **Mono Cable** - This cable is used with radios that do not have Receive Audio on the Mic jack. It is two feet in length. If you connect the Signalink USB to your radio's Data or Accessory Port, then you will NOT use this cable.
- **Jumper Wires** - These are used to configure the Signalink for your specific radio. **No soldering is required** - The jumpers simply push into a socket on the circuit board! The Signalink software CD contains [jumper settings](#) for the most popular radios. Settings for other radios can be easily obtained by following the step-by-step procedure in the Signalink manual, or by contacting our Technical Support Staff.
- **Allen Wrench** - Used to open the Signalink USB case.
- **Software CD** - This CD contains the latest programs for all of the most popular modes including PSK-31, SSTV, MT-63, CW, RTTY, AMTOR and Packet. Software for other modes can be downloaded from our [Signalink Software Page](#). The entire Tigertronics web site with all of the latest support information (including [jumper settings](#)) is also included on the CD.
- **Printed Installation Manual** - The Signalink manual contains both step-by-step, and "quick" installation instructions for users of all experience levels. Troubleshooting Tips and an Audio Level Adjustment procedure are also included.
- **FREE Telephone Tech Support** - If you have any questions, or if you need assistance with the installation of your Signalink, our Technicians are available to help you. Click [here](#) for information on contacting Tech Support.

**\*\*NOTE:** Due to the high cost of manufacturing the 13-pin DIN cable there is an additional \$5.00 charge for this item.

---

## Part Numbers & Options:

### Signalink USB Part Numbers (please specify when ordering):

- **SLUSB4R** - For 4-Pin Round Mic Connector
- **SLUSB8R** - For 8-Pin Round Mic Connector
- **SLUSBRJ1** - For RJ-11 Mic Connector
- **SLUSBRJ4** - For RJ-45 Mic Connector
- **SLUSB5PD** - For 5-pin DIN Data / Accessory Port Connector
- **SLUSB8PD** - For 8-pin DIN Data / Accessory Port Connector
- **SLUSB13I** - For ICOM 13-pin DIN Accessory Port Connector
- **SLUSB13K** - For Kenwood 13-pin DIN Accessory Port Connector
- **SLUSB6PM** - For 6-pin mini DIN Data / Accessory Port Connector
- **SLUSBNC** - Un-terminated cable (bare wires on radio end)

### Extra Radio Cables:

- **SLCAB4R** - For 4-Pin Round Mic Connector
- **SLCAB8R** - For 8-Pin Round Mic Connector
- **SLCABRJ1** - For RJ-11 Mic Connector
- **SLCABRJ4** - For RJ-45 Mic Connector
- **SLCAB5PD** - For 5-Pin DIN Data / Accessory Port Connector
- **SLCAB8PD** - For 8-Pin DIN Data / Accessory Port Connector
- **SLCAB13I** - For ICOM 13-Pin DIN Accessory Port Connector
- **SLCAB13K** - For Kenwood 13-Pin DIN Accessory Port Connector
- **SLCAB6PM** - For 6-Pin mini DIN Data / Accessory Port Connector
- **SLCABNC** - Un-terminated cable

### Accessories:

- **SLHEAD** - Signalink Programming Header

---

## Specifications\*\*:

Power Supply:	USB Port Powered
Audio Freq Response:	100Hz - 10Khz** **Upper frequency response is intentionally limited by Low Pass Filter.
Sampling Size/Rate:	16 Bits, All standard rates are supported up to 48Khz
Computer OS:	Windows 98SE, ME, 2000, XP & Vista MAC OS 9.1 or later MAC OS X 10.00 or later Linux

Computer Hardware:	This depends on the program that you are running (see your program's Help or ReadMe file for details). Most communications programs run fine on a 266Mhz or faster Pentium type processor, but some may require a faster computer.
Radio In/Out Z:	600 Ohm (nom). TX/RX Levels are fully adjustable for compatibility with Hi-Z and Low-Z radio connections.
Auto-PTT™ Delay:	Adjustable "Hang Time", 30 ms to 3 seconds
PTT Circuit:	Relay Rating - 3AMP (max)
Radio Connector:	TX Audio, RX Audio, PTT, GND - RJ-45 RX Audio/Speaker - 3.5mm Mono
Computer Connector:	USB 1.1/2.0 Compatible Standard USB "A" type connector
Other Connectors:	Aux. Speaker - 3.5mm Mono
Case:	Extruded Aluminum - 6061T4
Dimensions:	1.6" x 3.2" x 3.6"
Operating Temp:	-30C to +60C

\*\*Specifications are subject to change without notice. Tigertronics reserves the right to change specifications to improve our products, or for any other reasons that we deem necessary.

---

### Additional Information:

- April 2008 [QST Magazine Review](#) of the Signalink USB
- Read [Customer Comments](#) about the Signalink.
- See a [Product Comparison](#) between the Signalink USB and other interfaces.
- Compare the supported [Modes](#) of the Signalink USB to other interfaces.
- See the [Inside](#) or the [Rear View](#) of the Signalink USB.
- View the Signalink USB [Frequently Asked Questions](#) page.
- View the [Signalink USB Technical Questions, Operating Tips, & Troubleshooting FAQ](#)
- Download software from our [Signalink™ Software](#) page.
- Download the Installation Manual from the [Signalink Support Page](#).

- See [Price List](#) and [Ordering Information](#).
- 

Copyright © 1996-2008 Tigertronics - All Rights Reserved | BayPac, Signalink, and TigerTrak are trademarks of Tigertronics  
APRS is a trademark of Bob Bruninga | EchoLink is a trademark of Synergenics, LLC

All other trademarks are the property of their respective owners

**Signalink Jumper Settings & Wiring Information  
For Base & Mobile Radios**

**Warning:** Tigertronics has not verified the accuracy of all of the radio wiring information that is provided here. This information is provided for reference only and is NOT intended to replace the jumper installation procedure in the "Connecting The Radio" section of the Signalink Installation Manual. It is essential that you double-check this information against your radio's manual before doing the actual installation. While it is fairly simple to install the Signalink, it is possible to DAMAGE YOUR RADIO or the Signalink by incorrectly installing it!

**IMPORTANT NOTES**

- **Signalink USB Users** - The Signalink USB is always powered by the computer's USB jack. When installing the jumpers for the Signalink USB, please disregard the PWR jumper. All other jumper settings are the same. If you mistakenly install the PWR jumper, everything is OK as this pin is NOT connected inside the unit.
- **Select The Correct Diagram** - When viewing the jumper settings below, **BE CERTAIN THAT YOU ARE LOOKING AT THE CORRECT DIAGRAM** for the radio connector that you will be using. For any given radio, there are likely to be a different jumper settings for the Mic, Data and Accessory Port connectors.
- **Jumper Wire Color** - The jumper wires in the diagrams below are shown in color for illustrative purposes only. The color of the wires means nothing - they're just easier to see! The actual jumper wires that are included with the Signalink are all the same color and can be used to jumper any signal.
- **RJ-45 Mic Connectors** - There is a lack of standardization in the way that radio manufacturers number their RJ-45 mic connectors. We have numbered our connector according to the dominant industry standard (as shown below), and all jumper settings shown in our documentation reflect this standard. Icom and Radio Shack follow this standard, but Kenwood, Yaesu and some others do not. If your radio is not shown below and you need to figure out your own jumper settings, then you will need to carefully determine how *your* mic connector is numbered to avoid reversing connections!

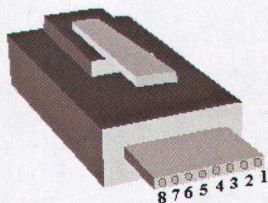

Signalink™, Industry Standard

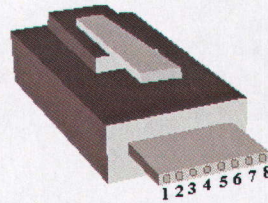

Kenwood, Yaesu, Some Others

- **PTT** - You should verify in your radio manual that the radio PTT requirements do not exceed the specifications of the Signalink keying circuit (please refer to the Signalink manual) and that the PTT line is "Grounded" to make the radio transmit. If your radio exceeds the specifications listed or requires some other keying arrangement, then please contact our Technical Support Staff for suggestions.
- **POWER** - The Signalink SL-1 and SL-1+ can usually be powered by the Accessory Voltage found on the Mic and Accessory Port connectors of most radios. If power is not shown in the jumper settings for your radio, then consult your radio manual to see if it is available. The Signalink SL-1 and SL-1+ requires **6.75 to 15 VDC** at 13ma (nominal). If this power is not available from your radio, then you will need to power the Signalink SL-1 or SL-1+ externally (see the Signalink manual for details). **Note that the Signalink USB is always powered by the computer, so you can disregard the PWR jumper when installing this unit.**
- **RECEIVE AUDIO / SPEAKER AUDIO** - Receive Audio is available on the Mic, Data, and Accessory Port connectors of most radios. If Receive Audio is not shown in the jumper settings for your radio, then consult your radio manual to see if it is available. If it is not, then you will need to connect a mono cable between your radio's External Speaker or headphone jack, and the "Speaker" jack on the back of the Signalink. See the Signalink Installation Manual for details.

**SELECT A MANUFACTURER**

**NOTE:** Please read the "Important Notes" above BEFORE you select your jumper settings. This will save time and may help prevent you from making a mistake that could possibly damage the Signalink or your radio. Note that the Signalink USB does NOT use the PWR jumper wire, so you can disregard this jumper during installation. All other jumper settings are the same.

<a href="#">ADI</a>	<a href="#">Alinco</a>	<a href="#">Azden</a>	<a href="#">Drake</a>	<a href="#">Elecrcraft</a>
<a href="#">ICOM</a>	<a href="#">JRC</a>	<a href="#">Kenwood</a>	<a href="#">Midland</a>	<a href="#">Radio Shack</a>
<a href="#">SGC</a>	<a href="#">Ten-Tec</a>	<a href="#">Yaesu</a>		

ADI

8-Pin Round Mic Connector (use SLUSB8R, SL1+8R, SL1-8R or SLCAB8R)

JP-1	Pin-out	Radio Models	Notes
	Pin 1 - Mic Input Pin 2 - PTT Pin 3 - N/C Pin 4 - N/C Pin 5 - N/C Pin 6 - Speaker** Pin 7 - N/C Pin 8 - GND	AR-146/147/446	**Speaker audio and power are available on some models. Check your radio manual for availability of these signals and add the appropriate jumpers.

TOP

ALINCO

8-Pin Round Mic Connector (use SLUSB8R, SL1+8R, SL1-8R or SLCAB8R)

JP-1	Pin-out	Radio Models	Notes
	Pin 1 - Mic Input Pin 2 - PTT Pin 3 - N/C Pin 4 - N/C Pin 5 - N/C Pin 6 - N/C** Pin 7 - GND Pin 8 - GND	ALD-24T ALR- 22T/22HT/72T DR-110T/112T DR- 130T/135E/135T DR-150/235T DR- 430T/435E/435T DR-510T/570T DR- 590T/592T/599T DR- 600T/610E/610T DR-620E/620T DX- 70T/70TH/70EH DX-77	**Speaker audio and power are available on some models. Check your radio manual for availability of these signals and add the appropriate jumpers.

RJ-45 Mic Connector (use SLUSBRJ4, SL1+RJ45, SL1-RJ45 or SLCABRJ4)

JP-1	Pin-out	Radio Models	Notes
	Pin 1 - N/C Pin 2 - N/C Pin 3 - N/C Pin 4 - PTT Pin 5 - Mic GND Pin 6 - Mic Input Pin 7 - GND Pin 8 - N/C	DR-605E/605T	Speaker audio and power are available on some models. Check your radio manual for availability of these signals and add the appropriate jumpers.

TOP

AZDEN

8-Pin Round Mic Connector (use SLUSB8R, SL1+8R, SL1-8R or SLCAB8R)

JP-1	Pin-out	Radio Models	Notes
	Pin 1 - Mic Input Pin 2 - GND Pin 3 - N/C Pin 4 - N/C Pin 5 - N/C Pin 6 - N/C Pin 7 - PTT Pin 8 - N/C	PCS 5000/6000 PCS 7000	Speaker audio and power are available on some models. Check your radio manual for availability of these signals and add the appropriate jumpers.

TOP

DRAKE

4-Pin Round Mic Connector (use SLUSB4R, SL1+4R, SL1-4R or SLCAB4R)

JP-1	Pin-out	Radio Models	Notes
	Pin 1 - Mic Input Pin 2 - PTT	TR-7/22/33 UV-3	Power is not available on this connector, so you will need to use



	Pin 3 - N/C Pin 4 - GND	external power for the Signalink Model SL-1+.
--	----------------------------	---

TOP

**Elecraft**

**8-Pin Round Mic Connector (use SLUSB8R, SL1+8R, SL1-8R or SLCAB8R)**

	<b>Pin-out</b> Pin 1 - Mic Pin 2 - PTT Pin 3 - NC Pin 4 - NC Pin 5 - NC Pin 6 - +5VDC Pin 7 - GND Pin 8 - GND	<b>Radio Models</b> K2 K3	<b>Notes</b> The Mic jack on the K2 can be wired a number of different ways, so before installing the jumper wires, you MUST verify that the pin-out of your K2 matches that shown here.  Sufficient power is not available on this connector, so you will need to use external power for the Signalink Model SL-1+.
--	---	---------------------------------	---

TOP

**ICOM**

**4-Pin Round Mic Connector (use SLUSB4R, SL1+4R, SL1-4R or SLCAB4R)**

	<b>Pin-out</b> Pin 1 - Mic Input Pin 2 - PTT Pin 3 - N/C Pin 4 - GND	<b>Radio Models</b> IC-22/202/215 IC-245/280/402/502 IC-551 IC-701	<b>Notes</b> Power is not available on this connector, so you will need to use external power for the Signalink Model SL-1+.
--	--	--	---

**8-Pin Round MIC Connector (use SLUSB8R, SL1+8R, SL1-8R or SLCAB8R)**

**IMPORTANT:** This diagram is for the MIC JACK only. If the Signalink is attached to your radio's 8-pin Accessory Port, then please see the diagram below under "8-pin DIN Accessory Port Connector".

	<b>Pin-out</b> Pin 1 - Mic Input Pin 2 - N/C** Pin 3 - N/C Pin 4 - N/C Pin 5 - PTT Pin 6 - GND Pin 7 - GND Pin 8 - Speaker**	<b>Radio Models</b> IC-1201/1271/1275 IC-22U/25/27/28 IC-228/229/251AE IC-255/260/271/290 IC-2400/2500 IC-37A/38A/375 IC-3200/3210/3220 IC-45/47/48 IC-471/475/490 IC-505/551/560/575 IC-707/718/720/725/726 IC-728/729/730/735 IC-736/737/738/740/745 IC-746/746PRO IC-756/756PRO IC-756PROII/PROIII IC-7400/7700/7800 IC-751/761/765/775/781 IC-820H/901/910	<b>Notes</b> **Speaker audio (usually Pin #8) and power (usually Pin #2) are available on some models. Check your radio manual for availability of these signals and add the appropriate jumpers.
--	--	---	--

**RJ-45 Mic Connector (use SLUSBRJ4, SL1+RJ45, SL1-RJ45 or SLCABRJ4)**

JP-1	Pin-out	Radio Models	Notes
	Pin 1 - +8V** Pin 2 - N/C Pin 3 - Speaker** Pin 4 - PTT Pin 5 - GND (mic) Pin 6 - Mic Input Pin 7 - GND Pin 8 - N/C	IC-207H**/208H** IC-281A/281E/281H IC-703/706/706MKII IC-2000 IC-2100H**/2200H** IC-2700**/2720H** IC-2800**/2820** IC-7000** IC-V8000** ID-800H**	**Speaker audio and power are available on some models. Check your radio manual for availability of these signals and add the appropriate jumpers.  **Speaker Audio is NOT available on the Mic jack of this radio.

**6-pin Mini DIN Data Port Connector (use SLUSB6PM, SL1+6PMD or SLCAB6PM)**

JP-1	Pin-out	Radio Models	Notes
	Pin 1 - Data In Pin 2 - Ground Pin 3 - PTT Pin 4 - 9600 Out Pin 5 - 1200 Out Pin 6 - Squelch	IC-207H/208H IC-2720H IC-2800** IC-2820 IC-703/706MKIIG IC-746PRO IC-7000 / 7400 IC-910H	For special signals requiring unfiltered "discriminator" audio, you will need to move the "SPKR" jumper to pin #4 (9600 baud output). Note that some newer radios do NOT provide this output, so this may not apply to your radio.  Power is not available on any 6-pin mini DIN Data Port, so you will need to use external power for the SignalLink Model SL-1+.  **Mic audio is NOT muted on this radio.

**8-pin DIN Accessory Port Connector (use SLUSB8PD, SL1+8PD or SLCAB8PD)**

**IMPORTANT:** This diagram is for the ACCY PORT only. If the SignalLink is attached to your radio's 8-pin Round Mic Jack, then please see the diagram above under "8-Pin Round MIC Connector".

JP-1	Pin-out	Radio Models	Notes
	Pin 1 - RTTY or N/C Pin 2 - Ground Pin 3 - Send Pin 4 - Mod In Pin 5 - AF Out Pin 6 - Squelch Pin 7 - +13.8V Pin 8 - ALC	IC-275A IC-707 IC-725/728/729 IC-735/736/737 IC-7400 IC-746** IC-746PRO** IC-756 / 756PRO IC-756PROII / III IC-761/765 IC-775/775DSP IC-781 IC-7700/7800 IC-820H/821H IC-910H	IC-756PRO users should use digital mode "D-USB" or "D-LSB".  **Some customers have reported that the IC-746 (early model only) does NOT mute the Mic when keyed from the Accy Port. If this is the case with your radio, then you will need to turn the radio's Mic Gain down and/or unplug the microphone.  **Due to the design of the IC-746PRO, this jack does NOT support VHF operation. If you want to operate both HF and VHF, then you'll need to use the 6-pin mini-DIN Data Port instead.  **IC-746PRO users should use "USB/LSB Data" mode (not regular USB/LSB).  IC-820H users need to set the Modulation Input Sensitivity switch to "Low", and the Baud Rate Selection switch to "AMOD".

**13-pin DIN Accessory Port Connector (use SLUSB13I, SL1+13PI or SLCAB13I)**

JP-1	Pin-out	Radio Models	Notes
	<p>Tigertronics manufactures a special cable for ICOM 13-pin Accessory Ports. If you would like to build your own 13-pin cable (not recommended!), please contact our Technical Support Staff for pin-out and wiring information.</p>	<p>IC-703 IC-706/706MKII IC-706MKIIG IC-718 IC-7000**</p>	<p>For VHF operation on the IC-706 and IC-706MKII you will need to move the PTT jumper to Pin #4.</p> <p>For VHF/UHF operation on the IC-706MKIIG and IC-7000, you should turn the following menu item to OFF:</p> <p>Item #30 for IC-706MKIIG</p> <p>Item #20 for IC-7000</p> <p>This will force the radio to use the same PTT pin for all bands so will not need to change the SignalLink's jumper settings.</p> <p><b>**This radio does NOT mute the Mic jack when using the Accy Port, so you will need to turn the Mic Gain down, or use the 6-pin Mini Din Data Port instead.</b></p>

**24-pin DIN Accessory Port Connector** - Tigertronics does not manufacture a cable for the ICOM 24-pin Accessory Port connector, but you can easily build one using our un-terminated radio cable (p/n SLCABNC). To build your cable, simply wire it straight-through for pin numbers 1-8 (Pin #1 to Pin #1, Pin #2 to Pin #2, etc.). Note that your cable MUST be wired straight-through or the jumper settings shown below will NOT work, and you might **DAMAGE YOUR RADIO OR THE SIGNALINK!**

JP-1	Pin-out	Radio Models	Notes
	<p>Pin 1 - NC Pin 2 - +13.8V Pin 3 - PTT Pin 4 - AF Out Pin 5 - Mic Input Pin 6 - NC Pin 7 - NC Pin 8 - GND Pins 9-24 NC</p>	<p>IC-251AE IC-730/751</p>	<p>Pins marked as "NC" are not used by the SignalLink, but might be connected internally inside the radio.</p>

TOP

**Japan Radio Company**

**8-Pin Round Mic Connector (use SLUSB8R, SL1+8R, SL1-8R or SLCAB8R)**

JP-1	Pin-out	Radio Models	Notes
	<p>Pin 1 - N/C Pin 2 - N/C Pin 3 - N/C Pin 4 - +9V Pin 5 - GND Pin 6 - PTT Pin 7 - Mic GND Pin 8 - Mic Input</p>	<p>JST-145/245</p>	

TOP

**KENWOOD**

**4-Pin Round Mic Connector (use SLUSB4R, SL1+4R, SL1-4R or SLCAB4R)**

JP-1	Pin-out	Radio Models	Notes
	<p>Pin 1 - Mic Input Pin 2 - PTT Pin 3 - GND Pin 4 - Mic GND</p>	<p>TR-7200A TR-7400A TR-7500 TS-120S/130S/180S TS-511S/520/530</p>	<p>Power is not available on this connector, so you will need to use external power for the SignalLink Model SL-1+.</p>

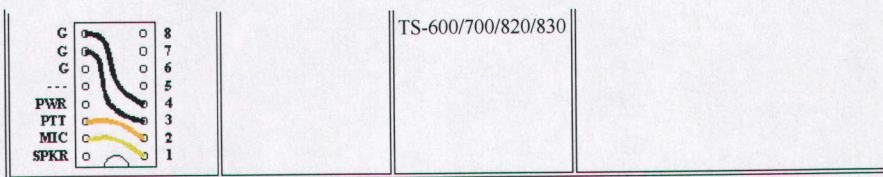

8-Pin Round Mic Connector (use SLUSB8R, SL1+8R, SL1-8R or SLCAB8R)

JP-1	Pin-out	Radio Models	Notes
	Pin 1 – Mic Input Pin 2 – PTT Pin 3 – N/C Pin 4 – N/C Pin 5 – 8 VDC** Pin 6 – Speaker** Pin 7 – Mic GND Pin 8 – GND	TM- 201/211/221/231 TM-241/2530/2550 TM-2570 TM- 321/331/3530/401 TM- 421/431/441/521 TM- 531/541/621/631 TM-701/721/731 TR-50/751/851 TS- 50/60/140/430/440 TS- 450/570/660/670 TS- 680/690/701/711 TS- 780/790/811/850 TS- 870/930/940/950 TS-2000 TW-4000/4100	**Speaker audio and power are available on some models. Check your radio manual for availability of these signals and add the appropriate jumpers.

RJ-45 Mic Connector (use SLUSBRJ4, SL1+RJ45, SL1-RJ45 or SLCABRJ4)

JP-1	Pin-out	Radio Models	Notes
	Pin 1 – NC Pin 2 – Speaker** Pin 3 – Mic Pin 4 – GND Pin 5 – PTT Pin 6 – GND Pin 7 – +8V** Pin 8 – NC	TM- 251/255/261/271/451 TM- 455/461/641/642 TM- 732/733/741/742 TM-941/942 TM-D700A TM-G707 TM-V7A/V71A TS-480HX/SAT	**Speaker audio and power are available on some models. Check your radio manual for availability of these features and add the appropriate jumpers.

6-pin Mini DIN Data Port Connector (use SLUSB6PM, SL1+6PMD or SLCAB6PM)

JP-1	Pin-out	Radio Models	Notes
	Pin 1 – Data In Pin 2 – Ground Pin 3 – PTT Pin 4 – 9600 Out Pin 5 – 1200 Out Pin 6 – Squelch	TM-251 TM-271/271A TM-451 TM-D700A TM-G707 TM-V7/V7A/V71A TS-480HX/SAT	For special signals requiring un-filtered "discriminator" audio, you will need to move the "SPKR" jumper to pin #4 (9600 baud output). Note that some newer radios do NOT provide this output, so this may not apply to your radio.  Power is not available on any 6-pin mini DIN Data Port, so you will need to use external power for the SignalLink Model SL-1+.

13-pin DIN Accessory Port Connector (use SLUSB13K, SL1+13PK or SLCAB13K) Our 13-pin cable works with ALL Kenwood radio's that have a 13-pin Accessory Port, however there are two possible jumper settings. If your radio is not listed in Figure 1 or Figure 2, then you will need to try both jumper settings to determine which PTT configuration your radio requires. We suggest that you try the settings in Figure 1 first. **Your radio will NOT be damaged if you install the**

**PTT jumper using the wrong configuration - you just won't be able to transmit!** After you have installed the jumpers, be sure to set the sound card audio levels as outlined in the Signalink manual. If you do not set the levels correctly, then the Signalink may not transmit, and you might mistake the problem for incorrect jumper settings. Note that external power is required for the Signalink Model SL-1+.

Figure 1	Figure 2	Notes
<p>This configuration is the most common and works with early Kenwood radios such as the TS-140, TS-450S, TS-870 and TS-950. Some newer radios such as the TS-570D and TS-2000/X also use these settings.</p>	<p>This configuration is less common and is used by some newer radios (TS-690 for example) and some older radios such as the TS-440. These settings are identical to those in Figure 1, except for the PTT jumper, which has been replaced by a diode module (supplied with cable).</p>	<p><b>TS-2000</b> users should set Menu 50F to 1200 Baud. Menu 50B can be used to increase the radio's power output if it is too low. We suggest that you change these menu items even if they already appear to be set correctly. Set 50B to zero, and then to five. Set 50F to 9600, and then to 1200. To increase the Receive Audio Level on the TS-2000, you can adjust menu 50C.</p> <p><b>TS-570</b> users should set Menu #33 to 1 or 2 (a setting of zero will result in no transmit power). Menu #34 should be set at 4-5 and can be increased to provide more Receive Audio if needed.</p>

TOP

**MIDLAND**

**4-Pin Round Mic Connector (use SLUSB4R, SL1+4R, SL1-4R or SLCAB4R)**

JP-1	Pin-out	Radio Models	Notes
	Pin 1 - Mic Input Pin 2 - GND Pin 3 - N/C Pin 4 - PTT	13-510	Power is not available on this connector, so you will need to use external power for the Signalink Model SL-1+.

TOP

**RADIO SHACK**

**RJ-45 Mic Connector (use SLUSBRJ4, SL1+RJ45, SL1-RJ45 or SLCABRJ4)**

JP-1	Pin-out	Radio Models	Notes
	Pin 1 - N/C Pin 2 - GND Pin 3 - N/C Pin 4 - N/C Pin 5 - Mic Input Pin 6 - PTT Pin 7 - N/C Pin 8 - N/C	HTX-212 HTX-242	Speaker audio and power are available on some models. Check your radio manual for availability of these signals and add the appropriate jumpers.

TOP

**SGC**

**8-Pin Round Mic Connector (use SLUSB8R, SL1+8R, SL1-8R or SLCAB8R)**

JP-1	Pin-out	Radio Models	Notes
	Pin 1 - Mic Pin 2 - PTT Pin 3 - NC Pin 4 - NC Pin 5 - NC Pin 6 - RX Audio Pin 7 - Mic GND Pin 8 - GNC	SGC-2020	Power is not available on this connector, so you will need to use external power for the Signalink Model SL-1+.

TOP

**TEN-TEC**

4-Pin Round Mic Connector (use SLUSB4R, SL1+4R, SL1-4R or SLCAB4R)

JP-1	Pin-out	Radio Models	Notes
	Pin 1 - Mic Input Pin 2 - GND Pin 3 - PTT Pin 4 - N/C	Pegasus	These jumper settings work with most Ten-Tec Mic jacks (not just the Pegasus). However you should verify that your radio has the same pin-out before installing them.  Power is not available on this connector, so you will need to use external power for the SignalLink Model SL-1+.

5-Pin DIN Accessory Connector - (use SLUSB5PD, SL1+5PD, or SLCAB5PD)

JP-1	Pin-out	Radio Models	Notes
	Pin 1 - Mic Input Pin 2 - GND Pin 3 - PTT Pin 4 - AF Output Pin 5 - NC	Argonaut V Jupiter Omni VII Pegasus	The Ten-Tec Jupiter must be in "Line" to use the ACCY jack (set in radio menu).  Power is not available on this connector, so you will need to use external power for the SignalLink Model SL-1+.

8-Pin DIN Accessory Connector - Orion & Orion II Only (use SLUSB8PD, SL1+8PD, or SLCAB8PD)

JP-1	Pin-out	Radio Models	Notes
	Pin 1 - Aux In Pin 2 - GND Pin 3 - PTT Pin 4 - Line Out** Pin 5 - NC Pin 6 - Line Out** Pin 7 - FSK Pin 8 - NC	Orion Orion II  <b>TEN-TEC Delta II Users: Our 8-pin DIN cable is NOT compatible with the TEN-TEC Delta II. You must connect the SignalLink to this radio's 4-pin Mic jack.</b>	**On the original Orion, the "Audio" menu determines what audio is available on pins 4 and 6, so the SPKR jumper will need to be set accordingly.  **On the Orion II, Pin #4 is ALWAYS the audio output.  Power is not available on this connector, so you will need to use external power for the SignalLink Model SL-1+.

TOP

YAESU

4-Pin Round Mic Connector (use SLUSB4R, SL1+4R, SL1-4R or SLCAB4R)

JP-1	Pin-out	Radio Models	Notes
	Pin 1 - GND Pin 2 - Mic Input Pin 3 - PTT Pin 4 - N/C		Power is not available on this connector, so you will need to use external power for the SignalLink Model SL-1+.

8-Pin Round Mic Connector (use SLUSB8R, SL1+8R, SL1-8R or SLCAB8R)

JP-1	Pin-out	Radio Models	Notes
	Pin 1 - N/C Pin 2 - N/C Pin 3 - N/C Pin 4 - N/C Pin 5 - N/C	FT-747/757 FT-757GX/767GX FT-840 FT-847** FT-890**	**On the FT-890, FT-990, FT-1000 and the FT-1000D, you should also jumper Pin #2 and Pin #5 to Ground.  **On the FT-847, FT-920, FT-950

	<p>Pin 6 – PTT Pin 7 – GND Pin 8 – Mic Input</p>	<p>FT-920** FT-950** FT-990** FT-1000/1000D** FT-1000MP** FT-2200 FT-5100</p>	<p>and FT-1000MP, you should also jumper Pin #5 to Ground.  Speaker audio and power are available on some models. Check your radio manual for availability of these signals and add the appropriate jumpers.</p>
--	--	---	--

RJ-11 Mic Connector (use SLUSBRJ1, SL1-RJ11, SL1+RJ11 or SLCABRJ1)

	<p><b>Pin-out</b> Pin 1 – N/C Pin 2 – N/C Pin 3 – +9V Pin 4 – GND Pin 5 – Mic Input Pin 6 – SW1 Pin 7 – N/C Pin 8 – N/C</p>	<p><b>Radio Models</b> FT-100** FT-1500M FT-1802 FT-2800M FT-7800R</p>	<p><b>Notes</b> **With the FT-100, the PTT jumper MUST be replaced with a standard 1/4 watt 27k resistor.  Other Yaesu models with an RJ-11 Mic jack might also use these same settings (check your radio manual).</p>
--	---	--	--

RJ-45 Mic Connector (use SLUSBRJ4, SL1+RJ45, SL1-RJ45 or SLCABRJ4)

	<p><b>Pin-out</b> Pin 1 – N/C Pin 2 – Speaker Pin 3 – PTT Pin 4 – Mic Input Pin 5 – GND Pin 6 – N/C Pin 7 – N/C Pin 8 – N/C</p>	<p><b>Radio Models</b> FT-2400 FT-2500</p>	<p><b>Notes</b> Speaker audio and power are available on some models. Check your radio manual for availability of these signals and add the appropriate jumpers.</p>
	<p><b>Pin-out</b> Pin 1 – N/C Pin 2 – N/C Pin 3 – N/C Pin 4 – Mic GND Pin 5 – Mic Pin 6 – PTT Pin 7 – GND Pin 8 – N/C</p>	<p><b>Radio Models</b> FT-450 FT-817 FT-897 FT-900</p>	<p><b>Notes</b> Power and Receive Audio are not available on this connector. Please see the SignalLink SL-1+ Installation Manual for instructions on providing External Power and Receive Audio.</p>

5-Pin Din Packet Connector (use SLUSB5PD, SL1+5PD or SLCAB5PD)

	<p><b>Pin-out</b> Pin 1 – Data In Pin 2 – GND Pin 3 – PTT Pin 4 – Data Out Pin 5 – NC</p>	<p><b>Radio Models</b> FT-920** FT-1000D/MP** FT-1000MPMKV** FT-1000MPMKV-Field** FT-2000 FTDX-9000/D/MP</p>	<p><b>Notes</b> Power is not available on this connector, so you will need to use external power for the SignalLink Model SL-1+.  **On the FT-920, the AFSK/FSK switch MUST be set to AFSK, and you must be in "Data" mode (push the front panel "Data" button). The Mic Gain control appears to affect the operation of the Packet jack, so we suggest setting this to 50% and then adjusting as needed.  **The FT-1000MPMKV and FT-1000MKV Field MUST be in "Packet" mode (NOT usb!) for digital operation. For PSK31 or other "USB" digital modes, you'll need to set your radio's "User Mode" (selection 8-6) to "PS31U". This will configure the radio to look at the Packet jack and use the correct side band for PSK31. For more detailed information on this (including settings for other modes),</p>
--	---	--	---

			see "Digital Modem Operation" in your radio manual.  <b>**This jack supports only FM and LSB, which is not compatible with the majority of digital modes.</b>
--	--	--	---

**6-pin Mini DIN Data Port Connector (use SLUSB6PM, SL1+6PMD or SLCAB6PM)**

JP-1	Pin-out	Radio Models	Notes
	Pin 1 – Data In Pin 2 – Ground Pin 3 – PTT Pin 4 – 9600 Out Pin 5 – 1200 Out Pin 6 – Squelch	FT-100/100D FT-817/817ND FT-450 FT-847** FT-857/897 FT-950 FT-1500M FT-7100/7800R FT-8100/8800R FT-8900R	For special signals requiring un-filtered "discriminator" audio, you will need to move the "SPKR" jumper to pin #4 (9600 baud output). Note that some newer radios do NOT provide this output, so this may not apply to your radio.  Power is not available on any 6-pin mini DIN Data Port, so you will need to use external power for the Signalink Model SL-1+.  <b>**On the FT-847 the Data Port supports VHF &amp; UHF Packet only.</b>

**FT-847 ONLY - 3.5mm Stereo "Data I/O" jack (use SLUSBNC, SL1+NC or SLCABNC)**

For the FT-847, we recommend that you attach the Signalink to the "Data I/O" jack. This jack works for all modes and will let you keep your microphone plugged into the radio. We do not stock a cable for this jack however, so you will need to build your own using one of our un-terminated radio cables (p/n SLCABNC). The picture below shows how to wire this cable and install the jumper wires.

**NOTE:** The values shown below for R1 and C1 have been used for years in a number of our products. You can use these values, or those shown in the FT-847 manual. Both will work just fine.

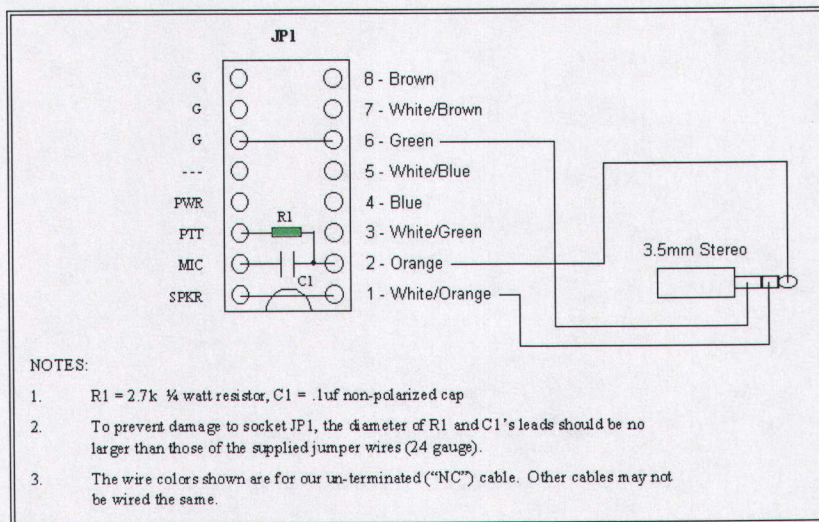

TOP



## Signalink Jumper Settings & Cable Wiring Diagram For HTs with a Combination Mic / PTT Line

**NOTE:** The diagram shown below is for a typical HT with a combination Mic/PTT line. Your radio may require different connections from those shown. Check your radio manual before installing the jumpers or building your radio cable, and be sure to read "IMPORTANT NOTES" below!

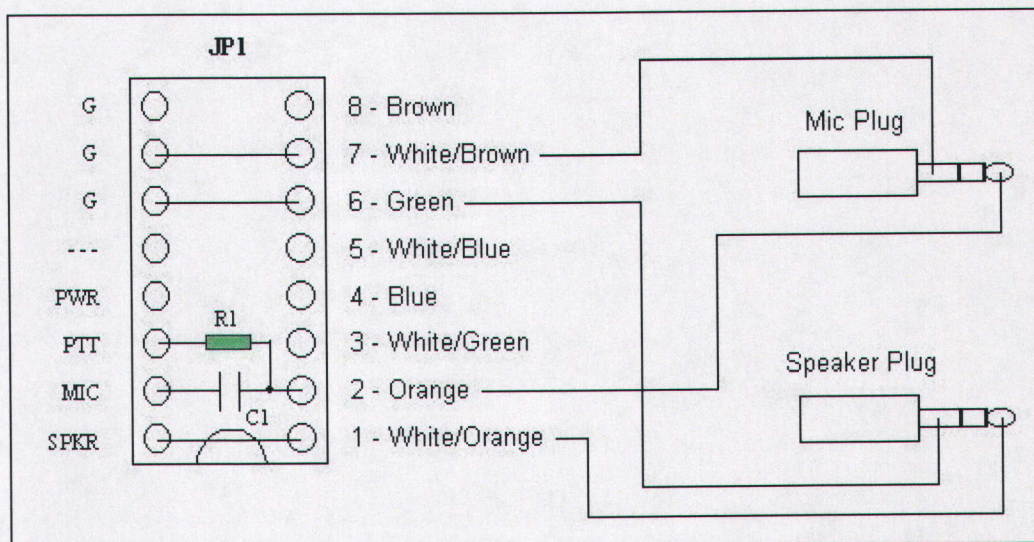

### IMPORTANT NOTES

- R1 should be a 2.7K 1/4 watt resistor
- C1 should be a .1uf non-polarized capacitor
- **To prevent damage to socket JP1, the diameter of R1 and C1's leads MUST be the same diameter as our jumper wires (24 gauge)**
- Your radio manual may show different values for R1 and C1. The values given here have been used successfully with virtually every radio available, and should work fine.
- The wire color code shown is for our un-terminated radio cable p/n "SLCABNC".

## Signalink Jumper Settings & Cable Wiring Diagram For HTs with a Separate Mic & PTT Lines

**NOTE:** The diagram shown below is for a typical HT with separate Mic and PTT lines. Your radio may require different connections from those shown. Check your radio manual before installing the jumpers or building your radio cable, and be sure to read "IMPORTANT NOTES" below!

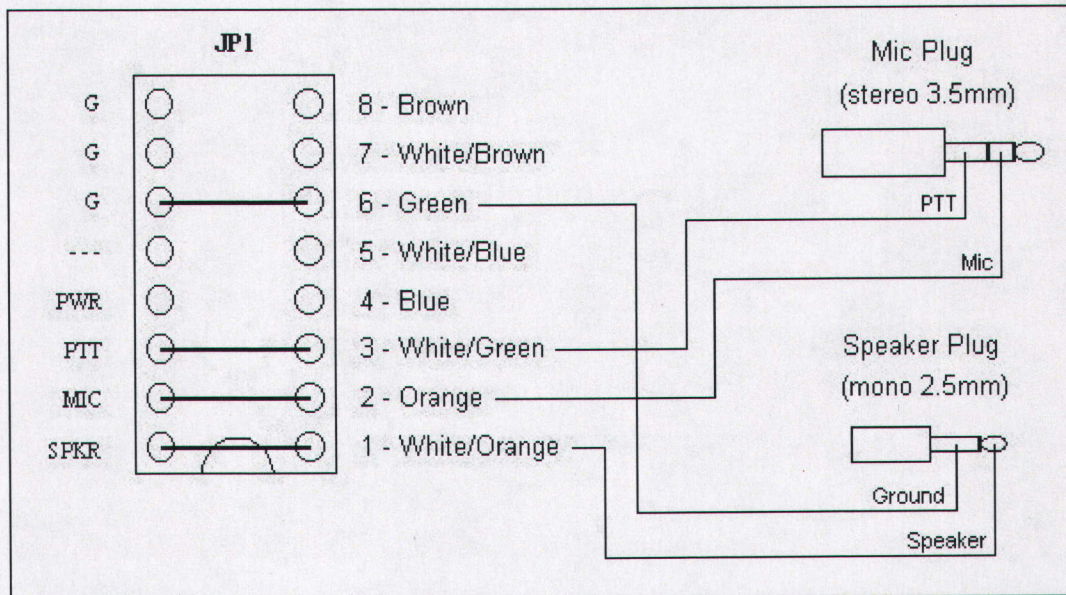

### IMPORTANT NOTES

- Be sure to use a STEREO connector if required by your radio!
- The wire color code shown is for our un-terminated radio cable p/n "SLCABNC".

Copyright © 1996-2008 Tigertronics - All Rights Reserved | BayPac, Signalink, and TigerTrak are trademarks of Tigertronics  
APRS is a trademark of Bob Bruninga | All other trademarks are the property of their respective owners