

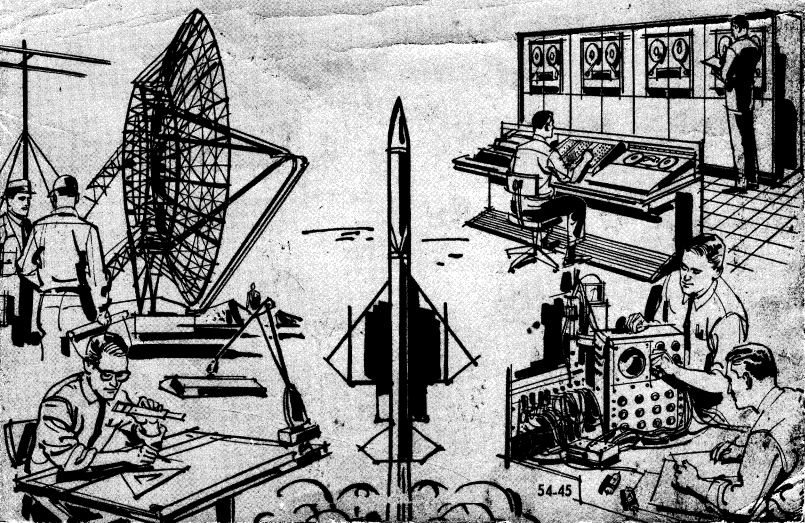


# OSCILLOSCOPE MANUAL

MODEL 54-45

**RCA INSTITUTES, Inc.**

A SERVICE OF RADIO CORPORATION OF AMERICA



# OSCILLOSCOPE MANUAL

## MODEL 54-45

---

### TABLE OF CONTENTS

ASSEMBLY INSTRUCTIONS.....	2
OPERATING INSTRUCTIONS.....	24
SECTION I. FEATURES AND SPECIFICATIONS.....	24
1-1. Features.....	24
1-2. Specifications.....	24
1-3. Function of Controls and Terminals.....	24
1-4. Notes on Controls and Terminals.....	25
SECTION II. OPERATION .....	25
SECTION III. APPLICATIONS.....	27
SECTION IV. MAINTENANCE.....	30
4-1. General.....	30
4-2. Removal from Cabinet.....	30
4-3. Trimmer Capacitor C1 Adjustment.....	30
4-4. Troubleshooting.....	32
SECTION V. SERVICE POLICY.....	35
SCHEMATIC DIAGRAM.....	36
PARTS LIST.....	37



**RCA INSTITUTES, Inc.**

A SERVICE OF RADIO CORPORATION OF AMERICA

**HOME STUDY SCHOOL**

**New York, N.Y.**

## UNPACKING YOUR KIT

To ascertain if you have received all of the parts required to build this kit, you may check the parts against the PARTS LIST.

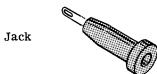
When unpacking each kit, handle all the parts carefully so that you will not damage any delicate components. DO NOT throw any packing material away until you have completely checked all the components. In some cases, there may be a loose component contained within the packing. In any case, whether you check the components against the parts list or not, it is advisable that you keep the container and the packing material stored some place until you have fully completed the kit.

## METHOD OF PART IDENTIFICATION

To enable rapid identification of electronic parts, each part has been assigned one or two letters of the alphabet called a "reference designation". These "reference designations" are nothing more than an initial letter or two representing the name of the part. For example, a tube socket has been assigned the "reference designation" letters "XV" and a resistor the letter "R". Thus, if you have ten sockets and 20 resistors in your kit, these parts would be identified by the designations XV1 through XV10 and R1 through R20, respectively.

## JACKS

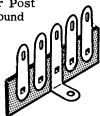
The reference designation assigned to receptacles (often referred to as jacks or binding posts) is the letter J. The different types of jacks used in this kit are so lettered and illustrated here as well as in the construction steps. In some cases, more than one jack is mounted on one bakelite strip and it is so noted.



## TERMINAL STRIPS

The various types of terminal strips are assigned the designation letters TB. A few types used in this kit are illustrated.

Four Post  
Ground



Two Post



1 Post Right  
and Ground



Two Post Left  
and Ground

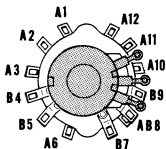


## SWITCHES

The reference designation assigned to switches may take several forms such as: switches that may be mounted on potentiometers and rotary switches.

On ROTARY SWITCHES, the front of the wafer is assigned one letter of the alphabet and the rear a second letter. Thus the front of the first wafer on S3 has been assigned letter "A", while the rear has been assigned letter "B".

In the ROTARY SWITCH shown, S3A-6 refers to switch S3, the rear of the wafer, (looking in from the rear) solder lug No. 6.



ROTARY SWITCHES are viewed from the rear and the pins are numbered in a counterclockwise manner.

#### FUSE AND FUSEHOLDER

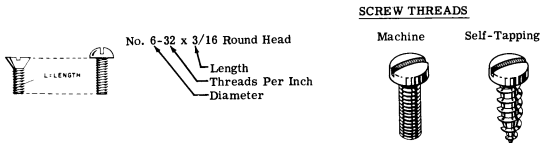
The fuse has been assigned the reference designation, F1, while the fuseholder is denoted by XF1.

#### HARDWARE

Hardware is a general term for mechanical parts used in the assembly of kits. Such items are usually screws, nuts and washers. Machine screws are sized in accordance with the diameters of the threaded portion (No. 2, No. 4, No. 6), with the smaller number denoting the smaller diameter. The second number indicates the number of threads to an inch.

Thus, a No. 6-32 screw has a No. 6 diameter with 32 threads per inch. The final number indicates the length of the threaded portion. A No. 6-32 x 3/8 screw has a 3/8" long threaded portion.

#### EXAMPLE:



#### SCREW HEADS

Binding Head



Set Screw (Headless)



Flat Head



Round Head



### NUTS



### Large Tinnerman



### Small Tinnerman



### LUGS

Small Solder  
(with lock)



Brass



Small Solder  
(without lock)



### WASHERS

Lock



Flat



Fibre



Rubber



The figure also shows the various head types in which these screws are supplied. Use the type specified in the particular step.

Washers and nuts are sized in accordance with the diameter of the screws they are used with.

Various types of washers are supplied. A lockwasher may have internal or external teeth. A flatwasher is made out of flat metal or plastic.

If after having checked all your components against the parts list, you find that you can not identify or are missing a component, please write us at:

Dept O  
RCA Institutes, Inc.  
350 West 4th St.  
New York, N. Y. 10014

If there is a slight hardware shortage, you can expedite matters by purchasing these pieces at your local jobber or hardware store.

USE THE BEST GRADE OF ROSIN CORE RADIO SOLDER ONLY. UNDER NO CIRCUMSTANCES SHOULD ACID CORE SOLDER OR ACID FLUX BE USED. The use of acid core solder or acid paste fluxes can cause serious corrosion and will VOID ALL THE REPAIR AND SERVICE GUARANTEES.

IMPORTANT: PLEASE READ CAREFULLY

### CONSTRUCTION HINTS

The various lengths of wire to be used in this kit are specified in the construction steps. After cutting the wire to the LENGTH SPECIFIED, strip the insulation 1/4" off each end. The exposed wire will be used to make the actual connection to the solder lug.

Components such as RESISTORS and CAPACITORS, may have longer leads than specified. Cut the leads to the length indicated in the particular construction step. This length is to be measured from the body of the component. In the case of insulated leads, strip 1/4" of insulation off from the ends and twist the strands (if any) of the wire together.

AS AN EXAMPLE, one step may specify that each lead on a resistor be cut to 1/2". 1/4" of each lead is used to make a mechanical connection to the solder lug. The other 1/4" is between the terminal board and the component so that the component will not be overheated when soldering.

When a CONNECTION is indicated, a (C) or an (S) will appear next to the lug involved. The (C) indicates that the connection should be simply mechanical. WITHOUT SOLDERING, since other leads are to be connected to this same lug. The (S) indicates that the connection should be made and soldered immediately. However, the (S) is always followed by a number, such as (S1), (S2), (S3), etc. This number indicates the NUMBER OF CONNECTIONS made and soldered to the lug. It is a check on the accuracy of your work.

AS AN EXAMPLE, if it says (S3) you should count three leads going to the lug to be soldered. If there are less than three leads at this particular lug, you will know that you have forgotten one or more leads, or connected them to the wrong lugs. If there are more than three leads, you can be certain you have connected an extra wire to this lug, which should probably go elsewhere.

WHEN YOU ASSEMBLE the parts in your unit, mark the symbol of each component on the chassis near the part, with a crayon. This will facilitate your wiring operation.

WHEN WIRING, lay the component in close to the chassis and dress it as shown in the drawing. BE CAREFUL to avoid shorts at the lugs. The book is written so that the wiring closest to the chassis usually gets wired in first. The next layer of wires are to be soldered in next. In each case, dress the leads and components as close to the chassis as possible.

NOTE: Although the pictorials are correct insofar as the connections made, they DO NOT in any way reflect the ACTUAL LENGTHS or PLACEMENT OF LEADS.

We may, in some cases, distort the actual component or lead placement to provide the kit building with a clearer illustration. Nevertheless, the wires and component leads must be cut according to the WRITTEN INSTRUCTIONS.

## THE STEPS

Next to each step you will find a number enclosed by a circle. This circled number corresponds directly to the dark circle number on the figures. These numbers refer to the particular step that the component is mounted or wired.

After you have completed each step, make a check mark or cross out the number next to the step so that you will have a complete record of your work.

Follow the steps in the sequence given in the book. DO NOT skip steps or pages unless otherwise specified.

NOTE: One of the most common errors that people make occurs when a step is not completely read BEFORE attempting any work on it. Please read the ENTIRE step first.

Once more, if any addenda sheets have been included in your books to modernize your kit or to make corrections or part substitutions, be sure to make these corrections first, before you start to assembly your kit.

You are now ready to construct your fine unit.

NOTE: Package 1 contains parts for	Figs. 1 and 2 (Study Group 5)
" 2 " "	Figs. 3, 4, 5 and 6 (Study Group 6)
" 3 " "	Figs. 7 and 8 (Study Group 7)
" 4 " "	Figs. 9, 10, 11 and 12 (Study Group 8)
" 5 " "	Figs. 13, 14, 15 and 16 (Study Group 9)
" 6 " "	Fig. 17 (Study Group 10)

### FIGURE 1

GENERAL: Secure the following nine TERMINAL STRIPS with one No. 6-32 x 5/16" screw, one No. 6 lockwasher and one No. 6-32 hex nut for each terminal strip.

1. ( ) Mount the 2 POST LEFT TERMINAL STRIP, TB1, to the bottom of the chassis and the 2 POST WITH GROUND TERMINAL STRIP, TB13, to the top of the chassis, as shown.
2. ( ) Mount the 2 POST LEFT WITH GROUND TERMINAL STRIP, TB2, to the bottom of the chassis and the 1 POST LEFT WITH GROUND TERMINAL STRIP, TB12, to the top of chassis, as shown.
3. ( ) Mount the 4 POST 3 RIGHT WITH GROUND TERMINAL STRIP, TB3, as shown.
4. ( ) Mount the 3 POST 2 RIGHT TERMINAL STRIP, TB4, as shown.
5. ( ) Mount the 2 POST WITH GROUND TERMINAL STRIP, TB5, as shown.
6. ( ) Mount the 4 POST WITH GROUND TERMINAL STRIP, TB6, as shown.
7. ( ) Mount the 4 POST WITH GROUND TERMINAL STRIP, TB7, as shown.
8. ( ) Mount the 3 POST 2 LEFT TERMINAL STRIP, TB8, as shown. SECURE it with one No. 6-32 x 1/4" flathead screw, one No. 6 lockwasher and one No. 6-32 hex nut.
9. ( ) Mount the 1 POST RIGHT WITH GROUND TERMINAL STRIP, TB9, as shown. SECURE it with one No. 6-32 x 1/4" flathead screw, one No. 6 lockwasher, and one No. 6-32 hex nut.
10. ( ) Mount the 4 POST 2 RIGHT WITH GROUND TERMINAL STRIP, TB11, as shown. Secure it with one No. 6-32 x 1/4" flathead screw, one No. 6 lockwasher, and one No. 6-32 hex nut.

GENERAL: SECURE the following six tube sockets with two No. 4-40 x 5/16" screws, two No. 4 lockwashers, and two No. 4-40 hex nuts for each socket.

11. ( ) Mount the 9 PIN MINIATURE TUBE SOCKET, XV5, as shown.
12. ( ) Mount the 9 PIN MINIATURE TUBE SOCKET, XV3, as shown.
13. ( ) First, place the 2 POST WITH GROUND TERMINAL STRIP, TB10, over the shank of the screw located near pin 7 on XV6. Then, mount the 7 PIN MINIATURE TUBE SOCKET, XV6, as shown.
14. ( ) Mount the 12 PIN COMPACTRON TUBE SOCKET, XV4, as shown.
15. ( ) Mount the 9 PIN MINIATURE TUBE SOCKET, XV2, as shown.
16. ( ) Mount the 9 PIN MINIATURE TUBE SOCKET, XV1, as shown.

GENERAL: Before going on with the next figure, please review all of the preceding steps pertaining to Figure 1 for any possible errors.

## FIGURE 2

1. ( ) Mount the (62017) SPDT SLIDE SWITCH, S1, as shown. SECURE it with two No. 4-40 x 1/4" flathead screws and two No. 4-40 Tinnerman nuts. Position the nuts so that the curved surface is facing the inside of the chassis.
2. ( ) Mount the (62017) SPDT SLIDE SWITCH, S4, as shown. SECURE it with two No. 4-40 x 1/4" flathead screws and two No. 4-40 Tinnerman nuts.
3. ( ) Insert four 1/8" RUBBER GROMMETS in the chassis, as shown.
4. ( ) Insert three 1/4" RUBBER GROMMETS in the chassis, as shown.
5. ( ) Mount the FUSEHOLDER, XF1, as shown. SECURE it with one 1/2" rubber washer and one 1/2" hex nut.
6. ( ) Mount two No. 8-32 TINNERMAN NUTS to the rear of the chassis, as shown.
7. ( ) Mount the LINE CORD in the STRAIN RELIEF. Hold the STRAIN RELIEF as shown in DETAIL A. Place the LINE CORD on the groove of the larger section and between both sections of the STRAIN RELIEF. Extend about 3" of the LINE CORD from the STRAIN RELIEF. Bend the smaller section over the LINE CORD and position it into the channels of the larger section. Compress the two sections together with a pair of pliers, gripping the larger diameter end of the STRAIN RELIEF. Pass the tinned ends of the LINE CORD through the hole on the rear of the chassis as shown.
8. ( ) Insert the large 1" RUBBER GROMMET in the rectangular cutout on the rear of the chassis, as shown.
9. ( ) The remaining step to complete Figure 2 appears further on in the book. DO NOT do it now, instead proceed with Figure 3.

GENERAL: Before going on with the next figure, please review all of the preceding steps pertaining to Figure 2 for any possible errors.

## FIGURE 3

1. ( ) Place the FRAME on your table with the holes facing up. Insert the FRONT PANEL into the frame with the nomenclature side, FACE DOWN. SECURE it with ten No. 6 x 1/4 type "F" P.H. SCREWS.
2. ( ) MOUNT the PLASTIC BEZEL to the front panel, as shown, using the next four steps to secure it.
3. ( ) Insert the (18110) 500K  $\Omega$  POTENTIOMETER/SPST SWITCH, R23/S5, through the bezel and through the hole marked "INTENS" on the front panel. Rotate the POT so that the lugs are



MIDWAY between the edge of the frame and bezel wall, as shown in the detail. SECURE it with one 3/8" flatwasher and one 3/8" hex nut, but do not tighten.

4. ( ) MOUNT the (16011) 2 MEGΩ POTENTIOMETER, R21, as shown. BEND the locating TAB out of the way. Use the mounting procedure described in Step 3.
5. ( ) MOUNT the (16011) 2MΩ POTENTIOMETER, R47, as shown. Use the mounting procedure described in Step 3. Rotate the pot so that the lugs are facing DOWN.
6. ( ) MOUNT the (18108) 100KΩ POTENTIOMETER, R12, as shown. Use the mounting procedure described in Step 3. Rotate the pot so that the lugs are facing DOWN. Tighten all the nuts on each of the pots.
7. ( ) MOUNT the pre-assembled FRONT PANEL to the chassis, as shown, using the remaining steps to secure it.
8. ( ) INSERT the (43001) 3/8" GROUND LUG over the shaft of the (18107) 10KΩ POTENTIOMETER, R8. MOUNT the POTENTIOMETER with GROUND LUG in the hole marked "VERT GAIN" on the front panel. Rotate the pot so that the locating tab slips into the oblong hole on the chassis. Position the GROUND LUG over the left lug on the POTENTIOMETER. SECURE it with one 3/8" flatwasher and one 3/8" hex nut.
9. ( ) INSERT the (43001) 3/8" GROUND LUG over the shaft of the (16006) 1MΩ POTENTIOMETER, R40. MOUNT THE POTENTIOMETER with GROUND LUG in the hole marked "HORIZ GAIN" on the front panel. Rotate the pot so that the locating tab slips into the oblong hole on the chassis. POSITION the GROUND LUG over the left lug on the POTENTIOMETER. SECURE it with one 3/8" flatwasher and one 3/8" hex nut.
10. ( ) MOUNT the (60120) ROTARY SWITCH WITH POT, S3/R36, in the hole marked "SWEEP RANGE/VERN" on the front panel. Rotate the switch so that the locating tab slips into the oblong hole on the chassis. SECURE it with one 3/8" flatwasher and one 3/8" hex nut.
11. ( ) MOUNT the NEON BULB, I1, to the panel. SECURE it by using one retaining ring. Rest the head of I1 on a block of wood and with the concave surface facing towards the panel, snap the ring into place over the casing shaft.
12. ( ) MOUNT the BINDING POST, J1, to the front panel as follows:
  - a. ( ) From the front of the panel insert one of the PLASTIC PLATFORMS into the double toothed hole on the panel (marked "VERT INPUT") making certain that the space between both pair of teeth on the PLATFORM locks into the teeth on the panel.
  - b. ( ) Place the threaded portion of the BINDING POST through the double "D" hole in the PLASTIC PLATFORM.
  - c. ( ) From the rear of the panel insert another PLASTIC PLATFORM over the threaded portion of the BINDING POST. Rotate until it locks into the hole. SECURE the assembly by using the hardware supplied in the following order: one No. 8 flatwasher, one No. 8 split washer, and one No. 8-32 hex nut. Then place one No. 8 brass lug over the body of the screw and secure it by using a No. 8-32 hex nut.
13. ( ) MOUNT BINDING POST, J3, into the hole on the panel marked "HORIZ INPUT", using the procedure described in Step 12.
14. ( ) MOUNT BINDING POST, J2, into the hole on the panel marked, "G", as follows:
  - a. ( ) From the front of the panel insert one of the PLASTIC PLATFORMS.

- b. ( ) Place the threaded portion of the BINDING POST through the double "D" hole in the PLASTIC PLATFORM.
- c. ( ) Secure the assembly from the rear of the panel using the hardware supplied in the following order: one No. 8 flatwasher, one No. 8 splitwasher, one No. 8-32 hex nut, one No. 8 brass lug, and one No. 8-32 hex nut.

GENERAL: Before going on with the next figure, please review all of the preceding steps pertaining to Figure 3 for any possible errors.

#### FIGURE 4

GENERAL: Unless otherwise indicated, all wire used is the type with THIN colored insulation.

- ✓1. ( ) Connect a 4" piece of BROWN WIRE from XV1-4 (S1) to XV2-5 (C).
- ✓2. ( ) Connect a 2-1/2" piece of YELLOW WIRE from XV1-5 (S1) to XV2-9 (C).
- ✓3. ( ) Connect a 4-1/2" piece of RED WIRE to TB4-3 (C). ROUTE the other end toward the front of the chassis as shown. It will be connected later.
- ✓4. ( ) Connect a 4" piece of RED WIRE from TB4-2 (C) to TB6-5 (C).
- ✓5. ( ) Connect a 3-1/2" piece of ORANGE WIRE from TB3-4 (C) to TB5-1 (C).
- ✓6. ( ) Connect a 3-1/2" piece of BLUE WIRE from TB3-3 (C) to TB5-3 (C).
- ✓7. ( ) Connect a 6" piece of GRAY WIRE to TB6-2 (C). ROUTE the other end toward the front of the chassis as shown. It will be connected later.
- ✓8. ( ) Connect a 4" piece of ORANGE WIRE from TB6-4 (C) to TB7-2 (C).
- ✓9. ( ) Connect a 3" piece of GREEN WIRE from TB6-1 (C) to TB10-3 (C).
- ✓10. ( ) Connect a 3" piece of YELLOW WIRE from XV4-1 (C) to XV6-4 (S1).
- ✓11. ( ) Connect a 4" piece of ORANGE WIRE to TB7-2 (C). ROUTE the other end through HOLE "C" to the top of the chassis. It will be connected later.
- ✓12. ( ) Connect a 4-1/2" piece of VIOLET WIRE to TB7-4 (C). ROUTE the other end through HOLE "C" to the top of the chassis. It will be connected later.

GENERAL: Before going on with the next figure, please review all of the preceding steps pertaining to Figure 4 for any possible errors.

FIGURE 5

- ✓ 1. ( ) Connect a 3/4" piece of BARE WIRE from XV1-1 (C) to XV1-3 (S1).
- ✓ 2. ( ) CUT a 5" piece of BLACK COAXIAL CABLE. STRIP off 3/4" of the outer insulation from both ends so that the braided shield is visible. DO NOT CUT the braid. Using a sharp pointed tool, UNRAVEL the exposed braids covering the INNER CONDUCTORS. Twist the strands together, then remove 1/4" of insulation from the CONDUCTORS. CUT OFF the BRAIDED SHIELD from one end and CONNECT the INNER CONDUCTOR of this end to XV1-2 (S1). ROUTE the other end to the front of the CHASSIS as shown. It will be connected later.
- ✓ 3. ( ) Connect a 2-1/2" piece of VIOLET WIRE from XV1-6 (S1) to TB4-1 (C).
- ✓ 4. ( ) Connect a 8" piece of THICK WHITE WIRE to XV2-1 (C). ROUTE the other end through hole "A" to the top of the chassis. It will be connected later.
- ✓ 5. ( ) Cut a 6" piece of BLACK COAXIAL CABLE as described previously. CUT OFF the BRAIDED SHIELD from one end and CONNECT the INNER CONDUCTOR of this end to XV2-2 (C). ROUTE the other end through the switch cutout to the front of the CHASSIS as shown. It will be connected later.
- ✓ 6. ( ) Connect a 3/4" piece of BARE WIRE from XV2-3 (C) to XV2-8 (C).
- ✓ 7. ( ) Connect a 5-1/2" piece of BROWN WIRE from XV2-5 (C) through XV2-4 (S1) to XV5-5C.
- ✓ 8. ( ) Connect a 3-1/2" piece of BROWN WIRE from XV2-5 (S3) to XV4-12 (C).
- ✓ 9. ( ) Connect a 2" piece of VIOLET WIRE from XV2-7 (S1) to TB4-1 (C).
- ✓ 10. ( ) Connect a 4" piece of YELLOW WIRE from XV2-9 (C) to XV4-1 (S2).
- ✓ 11. ( ) Connect a 3/4" piece of BARE WIRE from XV4-3 (S1) to XV4-6 (C).
- ✓ 12. ( ) Connect a 1/2" piece of BARE WIRE from XV4-4 (S1) to lug "X" (S1) on XV4.
- ✓ 13. ( ) Connect a 2-1/2" piece of GREEN WIRE from XV4-5 (S1) to TB6-1 (C).
- ✓ 14. ( ) Connect a 2-1/2" piece of GRAY WIRE from XV4-9 (S1) to TB6-2 (C).
- ✓ 15. ( ) CUT an 8-1/2" piece of BLACK SHIELDED CABLE as described previously. CUT off the BRAIDED SHIELD from one end and CONNECT the INNER CONDUCTOR of this end to XV4-11 (S1). ROUTE the other end along the chassis as shown. It will be connected later.
- ✓ 16. ( ) Connect a 3" piece of BROWN WIRE from XV4-12 (S2) to XV6-3 (S1).
- ✓ 17. ( ) Connect a 2-1/2" piece of VIOLET WIRE from XV6-7 (S1) to TB7-4 (C).
- ✓ 18. ( ) Twist a 13" piece of THICK BROWN WIRE and a 13" piece of HEAVY YELLOW WIRE together. Connect the YELLOW WIRE to XV5-9 (C). Connect the BROWN WIRE through XV5-5 (C), to XV5-4 (S1). ROUTE the other ends of the twisted pair through HOLE "C". It will be connected later.
- ✓ 19. ( ) Connect a 3" piece of ORANGE WIRE from TB5-1 (C) to TB6-4 (C).

- 20. ( ) Connect a 10" piece of BLUE WIRE to TB7-5 (C). ROUTE the other end along the chassis as shown.
- 21. ( ) Connect a 5-1/2" piece of GREEN WIRE to TB1-1 (C). ROUTE the other end through HOLE "B". It will be connected later.
- 22. ( ) Connect a 5" piece of YELLOW WIRE to TB1-2 (C). ROUTE the other end through HOLE "B". It will be connected later.
- 23. ( ) Pass 5" of a 15" piece of THICK BROWN WIRE through HOLE "F" to the top of the chassis. ROUTE the other end along the chassis, as shown. Both ends will be connected later.
- 24. ( ) Pass 5" of a 17" piece of THICK GREEN WIRE through HOLE "F" to the top of the chassis. ROUTE the other end along the chassis and through HOLE "C". Both ends will be connected later.

GENERAL: Before going on with the next figure, please review all of the preceding steps pertaining to Figure 5 for any possible errors.

### FIGURE 6

- 1. ( ) Connect a 10" piece of BLACK WIRE to XV1-1 (C). ROUTE the other end through HOLE "C". It will be connected later.
- 2. ( ) Connect a 10" piece of THICK GRAY WIRE to XV2-8 (S2). ROUTE the other end along the chassis as shown. It will be connected later.
- 3. ( ) Connect a 9" piece of THICK ORANGE WIRE to XV2-6 (C). ROUTE the other end through HOLE "E" to the top of the chassis. It will be connected later.
- 4. ( ) Connect a 12" piece of BLACK WIRE to XV6-2 (C). ROUTE the other end along the chassis as shown. It will be connected later.
- 5. ( ) Connect a 3/4" piece of BARE WIRE from XV5-3 (S1) to XV5-8 (C).
- 6. ( ) Connect a 4" piece of ORANGE WIRE to TB5-1 (C). ROUTE the other end along the chassis as shown. It will be connected later.
- 7. ( ) Connect an 8-1/2" piece of THICK BLUE WIRE TB5-3 (C). ROUTE the other end through HOLE "D" to the top of the chassis. It will be connected later.
- 8. ( ) Connect a 3" piece of RED WIRE from TB6-5 (C) to TB10-1 (C).
- 9. ( ) Connect a 5" piece of RED WIRE to TB10-1 (C). ROUTE the other end along the chassis. It will be connected later.
- 10. ( ) Connect a 5" piece of GRAY WIRE to TB7-1 (C). ROUTE the other end through HOLE "C" to the top of the chassis. It will be connected later.
- 11. ( ) Connect an 11" piece of THICK GREEN WIRE to TB3-5 (C). ROUTE the other end through HOLE "G" to the top of the chassis. It will be connected later.

12. ( ) Connect a 4-1/2" piece of GREEN WIRE from TB3-1 (C) to XV5-2 (S1).
13. ( ) Connect a 4-1/2" piece of YELLOW WIRE from XV2-9 (S3) to XV5-9 (C).

GENERAL: Before going on with the next figure, please review all of the preceding steps pertaining to Figure 6 for any possible errors.

### FIGURE 7

1. ( ) From XV1-2, CONNECT the INNER CONDUCTOR of the COAXIAL CABLE to R8-2 (S1). BEND the GROUND LUG toward R8-1. Connect the SHIELD to R8-1 and the GROUND LUG (C).
2. ( ) Connect a 1" piece of BARE WIRE from S1-3 (C) to J1 (S1).
3. ( ) Connect a 1" piece of BARE WIRE from S4-1 (C) to J3 (S1).
4. ( ) Cut both leads on a 10K $\Omega$ , 1/2 watt, 5% (brown, black, orange, gold) RESISTOR, R2, to 3/4". CONNECT from R8-1 (C) to S1-1 (C).
5. ( ) Cut both leads on a 500 uuf DISC CAPACITOR, C2, to 3/4". CONNECT one end to R8-1 (S4). (This includes soldering the GROUND LUG.) CONNECT the other end to S1-1 (C).
6. ( ) Cut both leads on a 10 ufd, 50V ELECTROLYTIC CAPACITOR, C4, to 1". CONNECT the minus (-) side to R8-3 (S1) and the positive (+) side to TB2-2 (C).
7. ( ) Cut both leads on a .1 ufd, 600V MYLAR CAPACITOR, C3, to 1-1/4". CONNECT from S1-2 (S1) to TB2-1 (C).
8. ( ) Cut both leads on a 990K $\Omega$ , 1/2W, 5% RESISTOR, R1, to 1/2". CONNECT from S1-1 (C) to S1-3 (C).
9. ( ) Cut both leads on the 1.5-6 uuf TRIMMER CAPACITOR, C1, to 3/4". CONNECT the side with the adjusting screw to S1-1 (S4) and the other side to S1-3 (S3).
10. ( ) Cut both leads on a .47 ufd, 200V MYLAR CAPACITOR, C14, to 1". Cover one lead with a 3/4" piece of tubing and connect to S4-2 (S1). CONNECT the other lead to S3B-5 (C).
11. ( ) BEND the GROUND LUG and SOLDER to R40-1. CONNECT a 2" piece of BROWN WIRE from R40-3 (S1) to S4-1 (S2).
12. ( ) Cut both leads on a 680K $\Omega$ , 1/2W, 10% (blue, gray, yellow, silver) RESISTOR, R35, to 3/4". CONNECT through S3A-8 (S1) through S3B-8 (S1) to R36-3 (S1).
13. ( ) From XV4-11, CONNECT the INNER CONDUCTOR of the COAXIAL CABLE to S3B-7 (S1). CONNECT the SHIELD to S3-"GG".
14. ( ) From XV6-2, CONNECT the BLACK WIRE to S3B-9 (C).
15. ( ) Cut the bottom lead on the NEON INDICATOR I1 to 1-1/2" and cover it with a 1-1/4" piece of tubing. Connect it to S3B-9 (S2). Cut the other lead to 3/4" and connect to J2 (S1).

16. ( ) Cut both leads of a .25 ufd, 600V MYLAR CAPACITOR, C7, to 3/4". CONNECT from TB3-1 (C) to S3A-6 (S1).
17. ( ) From TB6-2, CONNECT the GRAY WIRE to S3B-5 (S2).
18. ( ) CONNECT a 5-1/2" piece of GRAY WIRE from R40-2 (S1) to S3A-10 (S1).
19. ( ) From TB5-1, CONNECT the ORANGE WIRE to R36-2 (S1).
20. ( ) From XV2-8, CONNECT the heavy GRAY WIRE to S4-3 (S1).

GENERAL: Before going on with the next figure, please review all of the preceding steps pertaining to Figure 7 for any possible errors.

### FIGURE 8

1. ( ) Cut both leads on a 22K $\Omega$ , 1W, 10% (red, red, orange, silver) RESISTOR, R7, to 1/2". CONNECT from XV1-1 (S3) to TB4-2 (C).
2. ( ) Cut both leads on a 10K $\Omega$ , 1/2W, 10% (brown, black, orange, silver) RESISTOR, R6, to 1/2". CONNECT from TB2-2 (C) to TB2-3 (C).
3. ( ) Cut both leads on a 2.2M, 1/2W, 10% (red, red, green, silver) RESISTOR, R3, to 1/2". CONNECT from TB2-1 (C) to TB2-2 (C).
4. ( ) Cut both leads on a .003 ufd DISC CAPACITOR, C5, to 1/2". CONNECT from XV1-7 (C) to TB2-3 (C).
5. ( ) Cut both leads on a 560 $\Omega$ , 1/2W, 10% (green, blue, brown, silver) RESISTOR, R10, to 1/2". CONNECT from XV1-7 (S2) to TB2-3 (S3).
6. ( ) Cut both leads on a 680 $\Omega$ , 1/2W, 10% (blue, gray, brown, silver) RESISTOR, R5, to 1/2". CONNECT from XV1-8 (S1) to TB2-2 (S4).
7. ( ) Cut both leads on a 100 $\Omega$ , 1/2W, 10% (brown, black, brown, silver) RESISTOR, R4, to 1/2". CONNECT from XV1-9 (S1) to TB2-1 (S3).
8. ( ) Cut both leads on a 22K $\Omega$ , 2W, 10% (red, red, orange, silver) RESISTOR, R16, to 3/4". CONNECT from XV2-1 (S2) to TB5-1 (C).
9. ( ) Cut both leads on a .025 ufd, 200V MYLAR CAPACITOR, C6, to 3/4". CONNECT from XV2-2 (S2) to TB5-2 (C).
10. ( ) Cut both leads on a 10K, 1W, 10% (brown, black, orange, silver) RESISTOR, R14, to 3/4". CONNECT from XV2-3 (S2) to TB5-2 (C).
11. ( ) Cut both leads on a 22K $\Omega$ , 2W, 10% (red, red, orange, silver) RESISTOR, R15, to 1/2". CONNECT from XV2-6 (S2) to TB6-4 (S3).

12. ( ) Cut both leads on a 100 uuf DISC CAPACITOR, C15, to 3/4". CONNECT from XV4-2 (C) to XV4-7 (C).
13. ( ) Cut both leads on a 47K $\Omega$ , 1W, 10% (yellow, violet, orange, silver) RESISTOR, R33, to 3/4". CONNECT from XV4-2 (C) to TB6-5 (S3).
14. ( ) Cut both leads on a 4700 $\Omega$ , 1W, 10% (yellow, violet, red, silver) RESISTOR, R29, to 1/2". CONNECT from XV4-6 (S2) to TB6-3 (C).
15. ( ) Cut both leads on a 22K $\Omega$ , 1/2W, 10% (red, red, orange, silver) RESISTOR, R31, to 1/2". CONNECT from XV4-7 (C) to XV4-10 (C).
16. ( ) Cut both leads on a 56 uuf DISC CAPACITOR, C16, to 1/2". CONNECT from XV4-7 (C) to TB6-3 (C).
17. ( ) Cut both leads on an 18K $\Omega$ , 1/2W, 10% (brown, gray, orange, silver) RESISTOR, R30, to 3/4". CONNECT from XV4-2 (S3) to XV4-7 (S4).
18. ( ) Cut both leads on an 8200 $\Omega$ , 1/2W, 10% (gray, red, red, silver) RESISTOR, R34, to 1/2". CONNECT from XV4-10 (S2) to TB10-2 (S1).
19. ( ) Cut both leads on a 330K $\Omega$ , 1/2W, 10% (orange, orange, yellow, silver) RESISTOR, R51, to 1/2". CONNECT from XV6-2 (S2) to XV6-6 (C).
20. ( ) Cut both leads on a 47K $\Omega$ , 1W, 10% (yellow, violet, orange, silver) RESISTOR, R42, to 3/4". CONNECT from TB5-1 (S5) to XV5-6 (C).
21. ( ) Cut both leads on a 6.8K $\Omega$ , 1/2W, 10% (blue, gray, red, silver) RESISTOR, R38, to 1/2". CONNECT from XV5-7 (S1) to XV5-"GC" (S1).
22. ( ) Cut both leads on a .1 ufd, 400V, 20% MYLAR CAPACITOR, C8, to 3/4". CONNECT from XV5-1 (C) to TB3-5 (C).
23. ( ) Cut both leads on a 47K $\Omega$ , 1W, 10% (yellow, violet, orange, silver) RESISTOR, R41, to 3/4". CONNECT from XV5-1 (S2) to TB3-4 (C).
24. ( ) Cut both leads on a 2.2K $\Omega$ , 1W, 10% (red, red, red, silver) RESISTOR, R39, to 3/4". CONNECT from XV5-8 (S2) to TB3-2 (C).
25. ( ) Cut both leads on a 3.3M $\Omega$ , 1/2W, 10% (orange, orange, green, silver) RESISTOR, R43, to 1/2". CONNECT from TB3-5 (S3) to TB1-1 (C).
26. ( ) Cut both leads on a 470K $\Omega$ , 1/2W, 10% (yellow, violet, yellow, silver) RESISTOR, R44, to 1/2". CONNECT from TB3-4 (C) to TB1-1 (S3).
27. ( ) Cut both leads on a 470K $\Omega$ , 1/2W, 10% (yellow, violet, yellow, silver) RESISTOR, R45, to 1/2". CONNECT from TB3-4 (S4) to TB1-2 (C).
28. ( ) Cut both leads on a 3.3M $\Omega$ , 1/2W, 10% (orange, orange, green, silver) RESISTOR, R46, to 1/2". CONNECT from TB3-3 (S2) to TB1-2 (S3).
29. ( ) Cut both leads on a 2.2M, 1/2W, 10% (red, red, green, silver) RESISTOR, R37, to 1/2". CONNECT from TB3-2 (S2) to TB3-1 (S3).

GENERAL: Before going on with the next figure, please review all of the preceding steps pertaining to Figure 8 for any possible errors.

## FIGURE 9

1. ( ) Connect a 5-1/4" piece of RED WIRE to TB9-2 (C). ROUTE the other end through HOLE "C" to the top of the chassis. It will be connected later.
2. ( ) From TB10-1. CONNECT the RED WIRE to TB9-2 (C).
3. ( ) Cut both leads on a 10K $\Omega$ , 10W, 10% RESISTOR, R49, to 3/4". CONNECT from TB9-2 (S3) to TB7-2 (C).
4. ( ) Cut both leads on a 33K $\Omega$ , 1/2W, 10% (orange, orange, orange, silver) RESISTOR, R17, to 1/2". CONNECT from TB7-5 (C) to TB7-3 (S1).
5. ( ) Cut both leads on a 1.5M $\Omega$ , 1/2W, 10% (brown, green, green silver) RESISTOR, R18, to 3/4". CONNECT from TB7-5 (S3) to XV6-1 (C).
6. ( ) Connect a 16" piece of BLACK COTTON COVERED WIRE to TB8-2 (C) and a 16" piece of BLACK/WHITE COTTON COVERED WIRE to TB8-1 (C). Twist them together and ROUTE them through HOLE "H" to the top of the chassis. They will be connected later.
7. ( ) From HOLE "F" CONNECT the THICK BROWN WIRE to TB8-3 (C).
8. ( ) Connect one side of the LINE CORD to TB8-1 (S2) and the other side to XF1-1 (S1).
9. ( ) Connect a 9" piece of THICK BROWN WIRE to TB8-3 (C). ROUTE the other end through HOLE "C" to the top of the chassis. It will be connected later.
10. ( ) Cut both leads on a 270K $\Omega$ , 1/2W, 10% (red, violet, yellow, silver) RESISTOR, R27, to 1/2". CONNECT from XV3-9 (C) to TB8-3 (C).
11. ( ) Cut both leads on a .1 ufd, 1600V MYLAR CAPACITOR, C10, to 1". CONNECT from XV3-9 (S2) to TB9-1 (C). Raise the capacitor off the chassis.
12. ( ) Cut both leads on a .1 ufd, 1600V MYLAR CAPACITOR, C11, to 1". CONNECT from TB8-3 (C) to TB9-1 (S2). Raise the capacitor off the chassis.
13. ( ) Cut and strip the leads on the TRANSFORMER, T1 as follows:
  - ( ) One BLACK WIRE to 8" and the other to 11-1/2".
  - ( ) The BROWN WIRE to 2-1/2".
  - ( ) Both YELLOW WIRES to 2".
  - ( ) The WHITE WIRE to 2-1/2".
  - ( ) The BLUE WIRE to 2".
  - ( ) One RED/YELLOW WIRE to 1-1/2".
  - ( ) Both RED WIRES to 5-1/4".
  - ( ) One GREEN WIRE to 4-1/2" and the other to 7-1/2".



NOTE: The next step refers to Figure 2.

14. ( ) Mount the TRANSFORMER, T1, to the chassis and position it so that the RED WIRES face the REAR APRON as shown in Figure 2. SECURE it with four No. 8-32 x 3/8 screws, four No. 8 lockwashers and four No. 8-32 hex nuts.

NOTE: The next steps refer to Figure 9.

15. ( ) From T1 twist both BLACK WIRES together. Run them along the chassis, as shown. CONNECT the SHORT BLACK WIRE to TB8-2 (S2) and the LONG BLACK WIRE to XF1-2 (S1).

16. ( ) From T1, connect the SHORT GREEN WIRE to TB8-3 (S5).

GENERAL: Before going on with the next figure, please review all of the preceding steps pertaining to Figure 9 for any possible errors.

## FIGURE 10

1. ( ) From TRANSFORMER, T1, connect the following wires:

✓ a. ( ) Connect the RED/YELLOW WIRE to XV3-"GG" (S1).

✓ b. ( ) Connect the BLUE WIRE to XV3-4 (S1).

✓ c. ( ) Connect the WHITE WIRE to XV3-5 (S1).

✓ d. ( ) Route the LONG GREEN WIRE through HOLE "C". It will be connected later.

✓ e. ( ) Twist both RED WIRES together. Run them along the chassis, as shown. Connect one lead to XV6-1 (S2) and the other lead to XV6-6 (S2).

✓ f. ( ) Twist both YELLOW WIRES together. Connect one lead to XV5-5 (S3) and the other lead to XV5-9 (S3).

✓ g. ( ) Connect the BROWN WIRE to TB5-2 (S3).

2. ( ) Cut both leads on a .1 ufd, 400V, 20% MYLAR CAPACITOR, C9, to 3/4". CONNECT from XV5-6 (S2) to TB5-3 (S3).

3. ( ) Cut both leads on a 150K $\Omega$ , 1/2W, 10% (brown, green, yellow, silver) RESISTOR, R11, to 1/2". CONNECT from TB4-3 (S2) to TB4-2 (C).

4. ( ) Cut both leads on a 47K $\Omega$ , 1/2W, 10% (yellow, violet, orange, silver) RESISTOR, R9, to 3/4". CONNECT from TB4-1 (S3) to TB4-2 (S4).

5. ( ) Cut both leads on a .047 ufd, 1600V MYLAR CAPACITOR, C12, to 3/4". CONNECT from TB6-1 (S3) to TB7-1 (S2). Raise the capacitor off the chassis and away from the transformer.

6. ( ) Cut both leads on a  $150K\Omega$ ,  $1/2W$ , 10% (brown, green, yellow, silver) RESISTOR, R32, to  $1/2"$ . CONNECT from TB6-2 (S3) to TB6-3 (S3).
7. ( ) Cut both leads on a  $330\Omega$ ,  $2W$ , 10% (orange, orange, brown, silver) RESISTOR, R50, to  $3/4"$ . CONNECT from TB7-2 (S4) to TB7-4 (S3).
8. ( ) Cut both leads on a  $10K\Omega$ ,  $2W$ , 10% (brown, black, orange, silver) RESISTOR, R28, to  $3/4"$ . CONNECT from TB10-1 (S3) to TB10-3 (S2).

GENERAL: Before going on with the next figure, please review all of the preceding steps pertaining to Figure 10 for any possible errors.

## FIGURE 11

1. ( ) Mount the (24012) ELECTROLYTIC CAPACITOR, C13, to the REAR CHASSIS, as shown. (Note the triangle, semi-circle, and square on the bakelite base of the capacitor. Line up these symbols with the symbols drawn on the figure.) SECURE it by twisting the tabs  $1/4$  of a turn.

CAUTION: DO NOT twist the tabs excessively or they may shear off.

2. ( ) Insert the three SMALL RUBBER GROMMETS, as shown.
3. ( ) Insert both LARGE RUBBER GROMMETS, as shown.
4. ( ) Snap both No. 6-32 TINNEMAN NUTS into place.
5. ( ) Mount the POT BRACKET, as shown. SECURE it with two No. 6-32 x  $5/16$  screws, two No. 6 lockwashers, and two No. 6-32 hex nuts. Under one side place a No. 6 lug, as shown.
6. ( ) Snap the (18017) POTENTIOMETER, R19, to the bracket, as shown. Rotate the POT so that the lugs are facing the rear chassis.
7. ( ) Mount the REAR CHASSIS, as shown. SECURE it with three No. 6-32 x  $5/16$  screws, three No. 6 lockwashers, and three No. 6-32 hex nuts.
8. ( ) Mount the REAR BRACKET, as shown. SECURE it with two No. 6-32 x  $5/16$  screws, two No. 6 lockwashers, and two No. 6-32 hex nuts.
9. ( ) Mount the RED JACK, J6, to the BOTTOM of the REAR BRACKET, as shown. SECURE by pressing a retaining ring over the rear of the jack.
10. ( ) Mount JACKS J4, J5, and J7 to the REAR BRACKET, as shown. SECURE them by pressing a retaining ring over the rear of each jack.

GENERAL: Before going on with the next figure, please review all of the preceding steps pertaining to Figure 11 for any possible errors.

## FIGURE 12

1. ( ) From HOLE "F", connect the THICK GREEN WIRE to R23-2 (S1).
2. ( ) From HOLE "F", connect the THICK BROWN WIRE to R23-3 (S1).
3. ( ) From HOLE "B", connect the GREEN WIRE to R47-3 (S1).
4. ( ) From HOLE "B", connect the YELLOW WIRE to R47-1 (S1).
5. ( ) From the switch cutout, connect the RED WIRE to R12-3 (S1).
6. ( ) From the switch cutout, connect the INNER CONDUCTOR of the BLACK COAXIAL CABLE to R12-2 (S1). Connect the BRAIDED WIRE to TB12-2 (C).
7. ( ) From the switch cutout, connect the BLUE WIRE to S3A-11 (S1).
8. ( ) Connect a 5" piece of THICK ORANGE WIRE from R21-1 (S1) to TB12-1 (C).
9. ( ) Connect a 15" piece of THICK VIOLET WIRE to R21-2 (S1). Route the other end along the chassis, as shown. It will be connected later.
10. ( ) Connect a 7" piece of THICK BLUE WIRE from R21-3 (S1) to TB13-3 (C).
11. ( ) Connect a 5" piece of THICK BLUE WIRE from R23-1 (S1) to TB13-1 (C).

GENERAL: Before going on with the next figure, please review all of the preceding steps pertaining to Figure 12 for any possible errors.

## FIGURE 13

1. ( ) From HOLE "H", connect the BLACK/WHITE COTTON COVERED WIRE of the TWISTED BLACK/WHITE and BLACK pair to R23-4 (S1) and the BLACK COTTON COVERED WIRE to R23-5 (S1).
2. ( ) Cut both leads on a 100 ufd DISC CAPACITOR, C17, to 3/4". CONNECT from S3A-3 (S1) to TB13-2 (C).
3. ( ) Cut both leads on a .002 ufd DISC CAPACITOR, C18, to 1". CONNECT from S3A-2 (S1) to TB13-2 (C).
4. ( ) Cut both leads on a .022 ufd, 200V MYLAR CAPACITOR, C19, to 1". CONNECT from S3A-1 (S1) to TB13-2 (C).
5. ( ) Cut both leads on a 330K $\Omega$ , 1/2W, 10% (orange, orange, yellow, silver) RESISTOR, R48, to 1". CONNECT from R47-2 (S1) to TB13-2 (S4).

6. ( ) Cut both leads on a  $1M\Omega$ ,  $1/2W$ , 10% (brown, black, green, silver) RESISTOR, R22, to  $3/4"$ . CONNECT TB13-1 (S2) to TB13-3 (S2).
7. ( ) Cut both leads on a .22 ufd, 200V MYLAR CAPACITOR, C20, to 1". CONNECT from TB12-2 (C) to S3A-12 (S1).
8. ( ) Cut both leads on a  $56K\Omega$ ,  $1/2W$ , 10% (green, blue, orange, silver) RESISTOR, R13, to  $3/4"$ . CONNECT from R12-1 (S1) to TB12-2 (C).
9. ( ) Cut both leads on a  $4.7M\Omega$ ,  $1/2W$ , 10% (yellow, violet, green, silver) RESISTOR, R20, to  $1/2"$ . CONNECT from TB12-1 (S2) to TB12-2 (S4).

GENERAL: Before going on with the next figure, please review all of the preceding steps pertaining to Figure 13 for any possible errors.

### FIGURE 14

1. ( ) From HOLE "A", ROUTE the THICK WHITE WIRE through HOLE "J". It will be connected later.
2. ( ) From HOLE "E", ROUTE the THICK ORANGE WIRE through HOLE "I". It will be connected later.
3. ( ) From R21-2, ROUTE the THICK VIOLET WIRE through HOLE "J". It will be connected later.
4. ( ) From HOLE "G", ROUTE the THICK GREEN WIRE through HOLE "K". It will be connected later.
5. ( ) From HOLE "D", ROUTE the THICK BLUE WIRE through HOLE "L". It will be connected later.
6. ( ) Connect a 4" piece of ORANGE WIRE to R19-1 (S1). ROUTE the free end through HOLE "M". It will be connected later.
7. ( ) Connect a 5" piece of THICK RED WIRE to R19-2 (S1). ROUTE the free end through HOLE "M". It will be connected later.
8. ( ) Connect a 1" piece of BARE WIRE from R19-3 (S1) to lug "S" (S1).

GENERAL: Before going on with the next figure, please review all of the preceding steps pertaining to Figure 14.

### FIGURE 15

1. ( ) From HOLE "J", connect the THICK WHITE WIRE to XV7-7 (CRT socket) (S1).
2. ( ) From HOLE "I", connect the THICK ORANGE WIRE to XV7-6 (S1).

3. ( ) From HOLE "M", connect the ORANGE WIRE to C13-A (C).
  4. ( ) From HOLE "C", connect the ORANGE WIRE to C13-A (C).
  5. ( ) From HOLE "C", connect the RED WIRE to C13-B (S1).
  6. ( ) From HOLE "C", connect the VIOLET WIRE to C13-C (S1).
  7. ( ) From HOLE "C", connect the BLACK WIRE to C13-D (S1).
  8. ( ) From HOLE "C", connect the GRAY WIRE to TB11-4 (C).
  9. ( ) From HOLE "C", connect the THICK GREEN WIRE to TB11-5 (C).
  10. ( ) Connect a 4" piece of ORANGE WIRE from TB11-1 (C) to C13-A (S3).
  11. ( ) Connect a 3-1/2" piece of THICK BLACK WIRE from TB11-3 (S1) to J7 (S1).
  12. ( ) Connect a 3-1/2" piece of ORANGE WIRE from TB11-2 (C) to J6 (S1).
- GENERAL: Before going on with the next figure, please review all of the preceding steps pertaining to Figure 15 for any possible errors.

### FIGURE 16

1. ( ) Cut both leads on a 100K $\Omega$ , 1/2W, 10% (brown, black, yellow, silver) RESISTOR, R25, to 1/2". CONNECT from XV7-1 (C) to XV7-2 (S1).
2. ( ) Connect a 5" piece of THICK GRAY WIRE from TB11-4 (C) to XV7-3 (S1).
3. ( ) From HOLE "J", connect the THICK VIOLET WIRE to XV7-4 (S1).
4. ( ) From HOLE "M", connect the THICK RED WIRE to XV7-8 (S1).
5. ( ) From HOLE "K", connect the THICK GREEN WIRE to XV7-9 (S1).
6. ( ) From HOLE "L", connect the THICK BLUE WIRE to XV7-10 (S1).
7. ( ) From HOLE "C", twist the THICK BROWN WIRE (previously connected to TB8-3) and the GREEN COTTON COVERED WIRE together. CONNECT the GREEN WIRE to XV7-12 (S1) and the BROWN WIRE to XV7-1 (S2).
8. ( ) Cut both leads on a 100 $\Omega$ , 1/4W, 10% (brown, black, brown, silver) RESISTOR, R26, to 1/2". CONNECT from TB11-1 (S2) to TB11-2 (S2).
9. ( ) Cut both leads on a 330K $\Omega$ , 1/2W, 10% (orange, orange, yellow, silver) RESISTOR, R24, to 1/2". CONNECT from TB11-4 (S3) to TB11-5 (S2).
10. ( ) From HOLE "C", connect the BROWN WIRE of the TWISTED HEAVY BROWN and YELLOW pair to J5 (S1). Connect the YELLOW WIRE to J4 (S1).

GENERAL: Before going on with the final steps, please review all of the preceding steps pertaining to Figure 16 for any possible errors.

## FINAL STEPS

You have completed the assembly and wiring of your 54-45 OSCILLOSCOPE. When you have completed the final steps and Figure 17, your unit will be ready for use.

1. ( ) To catch any wiring errors, it is suggested that the entire wiring be checked point-by-point against the wiring instructions (and preferably against the schematic wiring diagram (Pg. 36) in your OPERATING INSTRUCTIONS) in order to become more familiar with the component layout and circuitry.

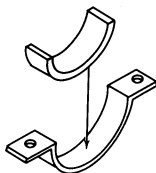
While doing so check for:

- a. rosin joints
  - b. loose lumps of solder
  - c. poor lead dress
  - d. accidental shorts
  - e. leakage paths arising from the flow of rosin between contacts. (REMOVE any rosin with a stiff brush dipped in alcohol.)
2. ( ) Insert all the tubes V1 through V6. DO NOT at this time, insert the CRT TUBE, V7. REFER to OPERATING INSTRUCTIONS PAGE 31 FIG. 7.
  3. ( ) Insert the 1 amp fuse, F1, into the fuseholder, XF1.
  4. ( ) Turn all switches and potentiometers on the FRONT PANEL to their EXTREME COUNTER-CLOCKWISE positions.
  5. ( ) INSTALL one LARGE DARK GRAY KNOB over the "VERT GAIN" SHAFT and one over the "HORIZ GAIN" SHAFT. Position each KNOB so that the WHITE LINE points downward on the FRONT PANEL. Tighten the setscrew in each knob.
  6. ( ) INSTALL one SMALL DARK GRAY KNOB over the "INTENS" SHAFT. Position the knob so that the WHITE LINE points vertically down (OFF POSITION). Tighten the setscrew.
  7. ( ) INSTALL one SMALL DARK GRAY KNOB over the "FOCUS" SHAFT. Position the KNOB so that the WHITE LINE points downward on the FRONT PANEL.
  8. ( ) INSTALL one SMALL DARK GRAY KNOB over the "VERT POS" SHAFT and one over the "HORIZ POS" SHAFT. Position each KNOB so that the WHITE LINE points in the same direction as the "FOCUS" KNOB.
  9. ( ) Place one OUTER CONCENTRIC KNOB over the "SWEEP RANGE/VERN." shafts with the white indicator pointing to the "HORIZ. EXT." mark. Tighten the setscrew.
  10. ( ) Insert one LIGHT GRAY INNER CONCENTRIC KNOB over the "SWEEP RANGE/VERN." shaft with the marker pointing downward.

11. ( ) DO NOT PLUG the unit into the AC Line.
  - ( ) Turn the unit on by turning the "INTENS" KNOB clockwise.
  - ( ) Check for a resistance of at least  $8\Omega$  across the AC line plug.
  - ( ) Check for a resistance of at least  $50K\Omega$  from XV6-7 to ground.
- If any resistance is smaller than the number specified, recheck the circuit.

**FIGURE 17**

1. ( ) Cut two 2-1/4" strips of the foam rubber supplied for both CRT CLAMPS. SECURE to the CRT CLAMPS by pressing them onto the clamps as shown.



Detail of Foam Rubber Mounting

2. ( ) Mount one side of both CLAMPS to the REAR CHASSIS using one No. 6-32 x 3/4" screw. Turn the screw just enough to catch the threads. The clamps should be loose enough to move up and down and rotate.
3. ( ) Place the SCREEN (the printed surface facing in) into the PLASTIC BEZEL.
4. ( ) Remove the backing from the four pieces of FELT. Place them on the inside surface of the four protrusions on the PLASTIC BEZEL.
5. ( ) Insert the CRT TUBE, V9, into the rear of the PLASTIC BEZEL. Rest the base of the tube on the bottom clamp.
6. ( ) Swing the TOP CLAMP over the base of the tube. Line up the holes and secure the tube by using another No. 6-32 x 3/4" screw.

**CAUTION**

Make certain that the CRT tube is into the PLASTIC BEZEL as far as it can go and the clamp is over the base.

Turn back on the screws a half a turn enough to allow the tube to rotate in the assembly for further alignment.

7. ( ) Place the CRT SOCKET, XV7, onto the protruding lugs of the CRT TUBE. NOTE KEYWAY.
8. ( ) Proceed to ADJUSTMENT PAGE 30, Section 4-3 in your OPERATING INSTRUCTIONS.

After the ADJUSTMENT is made on your unit, proceed with the remaining steps.

9. ( ) Insert the grooved portion of a PLASTIC FOOT into one of the four holes at the bottom of the CABINET.  
SECURE it by pressing the small protruding plastic cylinder into the foot so that the grooved portion expands and secures itself to the cabinet.  
( ) Mount the remaining three feet in a similar manner following the instructions above.
10. ( ) The handle as supplied comes with two rings attached. Place one of the handle mounting brackets over the exposed side of a ring and position on the top of the cabinet. Secure the bracket with two No. 6-32 x 1/4 flathead screws, two No. 6 flat metal washers, two No. 6 lock-washers and two No. 6-32 hex nuts. Secure the other ring and bracket in a similar manner.
11. ( ) Place the POWER JACK IDENTIFICATION LABEL (89353) in area just to the left of jacks.
12. ( ) Pass the line cord through the large cutout at the rear of the cabinet.  
Slide the unit into the cabinet. When it is properly mounted, the frame will fit snugly against the lip around the cabinet.  
SECURE it with two No. 8-32 x 3/8 SCREWS in the lower part of the cabinet.

NOTE: A removable GREEN FILTER is supplied with your kit. If you wish to use the filter, fold the tabs at right angles to the surface of the filter and insert into the FRONT of the PLASTIC BEZEL.

You have now completed building your fine instrument.

#### IN CASE OF DIFFICULTY

If the completed kit does not operate properly, refer to the MAINTENANCE section and read it thoroughly. The information provided may itself lead to a solution of the problem without outside assistance, and also includes the course of action you may take to obtain assistance from RCA Institutes, Inc. In any case, do not neglect the checking procedures which usually correct 90% of the difficulties that may be encountered. If you omitted to perform step 1 of the Final Steps "To catch any wiring errors.....", do it now, and do it thoroughly. Often, a person is unable to detect his own errors because he misunderstands an instruction. For this reason, have a friend go over the wiring with you, if possible. Also, do not neglect the obvious kind of mistake or trouble such as tubes or transistors placed incorrectly, shields not making proper contact, accidental shorting of leads or parts to the bottom plate, line cord plug making improper contact in outlet, blown fuse, etc.



## OPERATING INSTRUCTIONS

### SECTION I. FEATURES AND SPECIFICATIONS

The RCA Institutes Model 54-45 is a high quality, general purpose 3-inch CRT Oscilloscope with the performance capabilities required in general laboratory and service work.

#### 1-1. FEATURES

1. Compact, lightweight design. Fits on any bench, goes anywhere.
2. Flat-face CRT gives full utilization of face area.
3. Intensity and focus controls plus astigmatism adjustment.
4. 4-range sweep generator covers 10 cycles to 100,000 cycles.
5. 1500 volt high-voltage supply for sharp, bright trace. No blooming.
6. Full retrace blanking and fully automatic sync.
7. Removable green filter easily snaps into the front of the plastic bezel.
8. Permits external use of the power supply, with 400 VDC at 20ma and 6.3 VAC at 300ma, available at rear pin jacks.

#### 1-2. SPECIFICATIONS

**VERTICAL AMPLIFIER:** Flat  $\pm 3$ db from 2 cycles to 500kc; -6db at 1mc; 25-mv per cm sensitivity; frequency-compensated 100:1 coarse attenuator; input impedance 1 megohm shunted by 30pf; cathode follower input with fine attenuator in output; positioning range permits centering any part of trace expanded to three times CRT diameter.

**HORIZONTAL AMPLIFIER:** Flat  $\pm 3$ db from 2 cycles to 350kc; 1.3V per cm sensitivity; input impedance 1 megohm.

**SWEEP CIRCUIT:** 10 cycles to 100kc in four overlapping ranges; external or internal sync; fully automatic sync on all ranges; full retrace blanking; SWEEP RANGE switch also selects internal 60-cycle sine-wave sweep and input to HORIZ. INPUT terminals.

**CRT CIRCUIT:** Flat face 3-inch CRT: 1500 volts accelerating potential; intensity and focus controls on front panel; astigmatism adjustment without cabinet removal.

**TUBES:** 2-12AU7, 1-6BL8, 1-6D10, 1-6X4, 1-1V2, 1-CRT

**POWER REQUIREMENTS:** 105-125 volts, 60 cycles, 60 watts

**SIZE (HWD):** 8-1/2 x 5-3/4 x 11-1/4 inches

**WEIGHT:** 11 lbs.

#### 1-3. FUNCTIONS OF CONTROLS AND TERMINALS

The oscilloscope controls and terminals are easy to use once their functions are understood.

If the controls are divided into specific groups, for purposes of explanation, it will be easier to understand and keep in mind just what these functions are.

The INTENSITY & FOCUS controls together control the appearance of the trace. The INTENSITY knob controls the brightness of the trace and the FOCUS knob controls the sharpness or definition of the trace on the scope screen. The astigmatism control, a potentiometer accessible to screwdriver adjustment through a hole in the right-hand side of the cabinet, affects spot shape and is used to obtain a trace of uniform thickness. Proper adjustment of these controls should give a trace formed into a thin bright line. The INTENSITY & FOCUS controls interact to an extent; that is, adjustment of the FOCUS knob is usually necessary when the setting of the INTENSITY knob is changed.

The VERTICAL POSITION and HORIZONTAL POSITION controls adjust the location of the trace on the screen. Turning the HORIZONTAL POSITION knob shifts the trace left or right, and turning the VERTICAL POSITION knob moves the trace up or down.

The VERT. INPUT and ground terminals provide for connection of external signals to the vertical amplifier.

The VERTICAL-ATTENUATOR (LO-HI) switch provides a choice of no attenuation (LO) or 100:1 frequency compensated attenuation (HI) of the input voltage fed to the vertical amplifier.

The VERTICAL GAIN control allows continuous adjustment of the vertical amplifier gain. It is used with the VERT. ATTENUATOR selector to adjust trace height to the desired value.

The SYNC SELECTOR has two positions to permit selection of internal or external sync voltages for the sweep oscillator. At the INT. position, the synchronizing voltage is taken internally from the vertical amplifier. At the EXT. position, an external synchronizing voltage, applied between the HORIZ. INPUT terminal and ground, is fed to the sweep oscillator.

The SWEEP RANGE switch selects the frequency band over which the SWEEP VERNIER can be varied for frequency adjustment of the internal linear sweep, and also serves as the horizontal input selector. In the four most clockwise positions, the numbers above the position markers are the upper and lower limits of the band (approximately) covered by the SWEEP VERNIER at the particular position. At either of the two most counterclockwise positions of the SWEEP RANGE SWITCH. 60 CPS LINE and EXT. HOR., the sweep oscillator is disabled. At the 60 CPS LINE position, an a-c sine wave signal of power line frequency is taken from the power supply and applied to the input of the horizontal amplifier. At the EXT. HOR. position, an external signal voltage applied between the HORIZ. INPUT terminal and ground is applied to the input of the horizontal amplifier.

The HORIZONTAL GAIN control is effective only at the EXT. HOR. position of the SWEEP RANGE switch. It allows continuous adjustment of the horizontal amplifier-gain when an external signal voltage is applied to the HORIZ. input terminals. At all the internal sweep positions and the 60 CPS LINE position, fixed full screen horizontal deflection is obtained.

#### 1-4. NOTES ON CONTROLS AND TERMINALS

1. Proper trace definition will be obtained if the astigmatism control is correctly adjusted, and the 'scope is not operated in strong fields such as are found near transformers, transmitters, and power generating equipment, etc., which may distort the electron beam that produces the trace.

2. A sharply focused short line, or a small spot of high intensity, should not be permitted to remain stationary on the screen for any considerable length of time (more than 1/2 minute), or the screen will be burned. A trace of excessively high intensity will burn the screen in 3 to 5 minutes. These burned portions of the screen will no longer fluoresce and are useless for observation. If it is required to have a fixed trace on the screen for a long period, reduce the trace intensity to minimum.

3. Trimmer capacitor C1 is used for frequency compensating the vertical attenuator at the 100:1 (HI) position. See MAINTENANCE section for adjustment procedure.

4. The EXT. position of the SYNC SELECTOR is for use with generators of other devices which have sync outputs.

5. At maximum gain settings, the sensitivity of the amplifiers is very high. Under these conditions stray pickup may produce patterns on the screen when no signal source is connected to the vertical input terminals. This is normal and does not interfere with the 'scope operation.

#### SECTION II. OPERATION

NOTE: To obtain proper results with your 'scope, it is advisable to become acquainted with functions and correct use of the panel controls and terminals by making some simple

tests. These tests will also assure you that the instrument is in proper working condition. However, do not attempt this procedure before all final checks have been completed and initial adjustments have been made as described in the MAINTENANCE section.

1. Set the INTENSITY, VERT. GAIN and HORIZ. GAIN CONTROLS at their furthest counter-clockwise positions. Set the SWEEP RANGE switch at EXT. HORIZ.
2. Set the FOCUS, VERT. POS., and HOR. POS. controls at the center of their ranges. All other controls may be set at any position.
3. Insert the power cord into a 105-125 volt, 60 cycle a-c outlet.

**WARNING**

This instrument will not operate, or operate improperly and even be seriously damaged if connected to any other type of power line (such as dc, 25 cycle ac, or an ac line above 125 volts).

4. Turn the INTENSITY control clockwise (on), and the pilot lamp should light. Allow the unit to warm up for about a minute. Then gradually turn the INTENSITY control clockwise until a spot appears somewhere on the screen of the cathode-ray tube. If the spot does not appear, adjust the VERT. POS. and HOR. POS. controls slightly, as the spot may be off screen.

5. Adjust the VERT. POS. and HOR. POS. controls until the spot is in the exact center of the screen, and then adjust the FOCUS control for the sharpest image. Do not make the spot too bright! Notice that for every setting of the INTENSITY control, there is a best setting for the FOCUS control. Now adjust the astigmatism control on the right hand side of the cabinet for the smallest, roundest spot possible.

6. Set the SWEEP RANGE switch at any of the internal linear sweep positions. Note that the spot extends to a horizontal line. This is the linear horizontal sweep. The sweep has a fixed amplitude designed to provide full screen horizontal deflection, and is not affected by the HORIZ. GAIN control.

7. Set the SWEEP RANGE switch at EXT HORIZ. Notice that the horizontal line returns to a spot, as the horizontal amplifier is now connected to the HORIZ. INPUT and ground terminals. Any signal applied to the HORIZ. INPUT and ground terminals will cause the line to lengthen horizontally in proportion to the peak value of the applied signal. In this position the HORIZ. GAIN control is effective.

8. Set the SWEEP RANGE switch at 60 CPS LINE. The horizontal line on the screen is the 60-cycle sine sweep, having a fixed amplitude designed to provide full screen horizontal deflection. Here again, the HORIZ. GAIN control has no effect.

9. Connect one of the 6.3 VAC jacks at the rear to the VERT. INPUT terminal. Set the SYNC SELECTOR at INT., the VERT. ATTENUATOR at LO, the SWEEP RANGE switch at 10-100, the SWEEP VERN. control at MIN. Now adjust the VERT. GAIN control until the pattern extends about two-thirds the height of the cathode-ray tube. The pattern will not be clear because of its rapid horizontal drift. Advance the setting of the SWEEP VERNIER gradually until two sinewaves of power line frequency appear and remain stationary on the screen.

NOTE 1: In rotating the SWEEP VERNIER, it will be noticed that the drift of the pattern slows down as certain critical frequencies are approached, and then reverses direction when the critical frequency is passed. At these critical frequencies, a clear pattern can be discerned. These critical sweep frequencies are sub-multiples of the signal frequency, or the signal frequency itself (when only one cycle of the signal is displayed). The pattern is locked in at sub-multiples of the signal frequency when it is desired to view more than one cycle of the signal. The sweep frequency is equal to the signal frequency divided by the number of complete cycles displayed on the screen. For example, if two complete cycles of the 60 cps signal are displayed, the sweep frequency is 30 cps.

NOTE 2: At low sweep frequencies, flickering of the pattern is normal due to the slow writing speed of the spot and the persistence of the screen, which together are insufficient to cause the motion to blend into a fixed image.

### SECTION III. APPLICATIONS

GENERAL: The oscilloscope is an instrument designed for viewing electrical oscillations and transients. Phenomena having a repetition rate from a few cycles per second to several megacycles per second may be displayed on a 'scope.

WAVEFORM INVESTIGATION: When the output of the internal sweep generator is fed to the horizontal channel, the pattern on the screen is actually a graph showing the variation with time of the instantaneous amplitude of the signal applied to the vertical channel. The sweep frequency is usually a sub-harmonic of the signal frequency, so that several complete cycles of the signal are displayed on the screen.

DISPLAY OF WAVEFORMS: Displaying a waveform means obtaining a picture that shows how the amplitude of the signal under observation varies with time. It is generally most convenient to use a time-base signal that varies linearly with time, so that equal intervals of time are represented on the screen by equal intervals of distance along the same axis. The sawtooth output of the sweep generator gives such a time-base on the horizontal axis, the time (in seconds) represented by the overall horizontal deflection being equal to the reciprocal of the sweep frequency (in cycle per second).

If the frequency of the observed signal is equal to the sweep frequency, one complete cycle will be observed on the screen. If the frequency of the applied signal is twice the sweep frequency, two complete cycles will be obtained on the screen and so on. Fig. 1 is a projection drawing of a sine wave applied to the vertical plates and sawtooth wave of the same frequency applied to the horizontal plates. Fig. 2 is a projection drawing showing the resultant pattern when the frequency of the sawtooth is one-half that employed in Fig. 1.

In these figures, points that occur simultaneously are numbered the same. The circle represents the tube screen. If simultaneous projections were drawn from every point on each wave, the intersections would trace out the sine waves shown in the circles. The sections of sawtooth between 1 and 4 in Fig. 1 and between 1 and 9 in Fig. 2 are the sweep sections during which the displays are produced. The sections of the sawtooth between 4 and 5 in Fig. 1 and between 9 and 10 in Fig. 2 are the sections during which the beam is returned very rapidly to the starting point at the left-hand side of the screen.

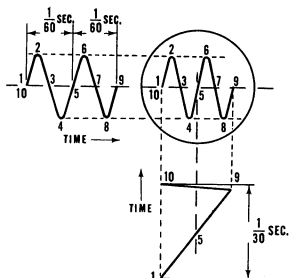
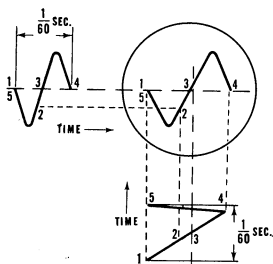


Figure 1. 1 Cycle of Sine Wave vs. Sawtooth

Figure 2. 2 Cycles of Sine Wave vs. Sawtooth

**LISSAJOUS PATTERNS:** Another type of fundamental pattern is obtained when both the vertical and horizontal deflection voltages are sinewaves that are related in frequency as follows: one frequency is a whole number of times larger than the other; one frequency is a simple fraction of the other. When one or the other of these conditions is fulfilled, stationary closed-loop patterns are obtained. These patterns are called Lissajous figures after the 19th century French scientist. They are particularly useful in determining the frequency ratio between two sinewave signals. If the frequency of one signal is known, the frequency of the other signal can be easily determined from the frequency ratio. Usually the known signal is applied to the horizontal channel and the unknown signal to the vertical channel. The shape of the pattern changes with the phase relationship between the known and unknown signals. For example, all the patterns shown in Fig. 3 (and those intermediate) are possible with a frequency ratio of 1:1 if the phase differences indicated exist.

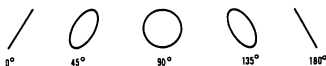


Figure 3. 1:1 Ratio of Lissajous Patterns

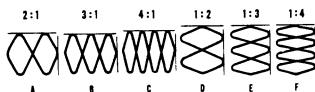


Figure 4. Lissajous Patterns

In general, to determine frequency ratio from the Lissajous figure, count the number of points of tangency to horizontal and vertical lines, drawn or imagined (see Fig. 4). Points of tangency at the top of the figures result from the unknown frequency applied to the vertical channel. Those at the side of the figure result from the known frequency applied to the horizontal axis. As a matter of fact, the following relationship holds true in all cases:

$$\frac{\text{V axis freq}}{\text{H axis freq}} = \frac{\text{V pts of tangency}}{\text{H pts of tangency}}$$

As an example, take Fig. 4c, which shows four points of tangency at the top and one point at the side. This indicates that the unknown frequency applied to the vertical axis is four times the known frequency. In Fig. 4f, one point of tangency at the top and four at the side indicate that the unknown frequency is one-fourth the known frequency.

An Audio Generator (or Electronic Switch) having a square wave output can be used to check amplifiers as to frequency response, phase shift, transient response, deficient design, or faulty components. The equipment is set up as shown in Fig. 5.

First, as a means of comparison, the square wave output from the Audio Generator is viewed on the scope. The horizontal sweep of the scope should be adjusted so that at least two full cycles can be seen on the screen. (Fig. 6a shows one full cycle of a perfect square wave). The 'scope is then connected to the output of the amplifier under test so that the modified square wave can be viewed on the screen. Possible output wave shapes are shown in Fig. 6b to 6i, and the significance of each waveshape is explained below.



Figure 5. Equipment Test Block Diagram

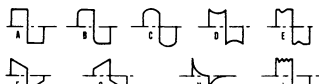


Figure 6. Sample Output Wave Shapes

Fig. 6b shows "rounding" of the leading edge of square wave. This indicates a drop off in gain at high frequencies. "Rounding" will generally be observable when there is a substantial drop in the gain by the tenth harmonic (or less). Therefore, if a 2kc square wave fed to the amplifier is reproduced on the 'scope without "rounding", the amplifier is flat to  $10 \times 2kc = 20kc$ .

Fig. 6c shows the effect of increased gain and Fig. 6d shows the effect of decreased gain at the square wave frequency. Fig. 6e indicates lowered gain in a narrow frequency band. If the square wave frequency is brought into this narrow frequency band, Fig. 6d will result.

The effect of phase shift in the amplifier is shown in Figs. 6f and 6g. If, at low frequencies, there is phase shift in the leading direction, the square wave will be tilted as in Fig. 6f. If there is phase shift in the lagging direction, the top of the square wave will be tilted as in Fig. 6g. The steepness of the tilt is proportional to the amount of phase shift. Phase shift is not important in audio amplifiers, although the ear is not entirely insensitive to it. In television and 'scope amplifiers, however, phase shift should be at a minimum.

Fig. 6h shows the pulse output from the amplifier that results when the square wave has undergone differentiation. This will happen when the grid resistor or the coupling condenser is too low in value or if the coupling condenser is partially open. Lastly, Fig. 6i, shows a square wave with damped oscillations following the leading edge. This results when a high frequency square wave is fed to an amplifier in which distributed capacitances and lead inductances resonate at low frequencies. In television and 'scope amplifiers it may result from an undamped peaking coil.

High fidelity audio amplifiers may be given a rapid check by testing first with a square wave of fundamental frequency not less than 3 to 4 times the low frequency limit of the amplifier (3db point), and then with a square wave of fundamental frequency which may be anywhere between  $1/100$  to  $1/10$  of the high frequency limit of the amplifier depending upon how many harmonics are considered necessary to produce an acceptable version of a square waveform. Usually, square waves of fundamental frequency from 40 to 60 cps and 1000 to 2000 cps are employed to cover the range up to 20,000 cps.

To insure correct results, the following is suggested: Connect the proper value of load across the amplifier output terminals; use a low capacitance cable for connecting the generator to the amplifier input; set the generator output to an ample value, but be sure not to overload the amplifier. The square wave signal is fed to the amplifier input and the 'scope is connected across the amplifier load

Use the internal linear sweep to observe the waveform. Note that tone controls have a very marked effect on the square wave response and should be set to the "flat" positions unless it is desired to observe their effect. Note, also, that low fidelity and p.a. amplifiers will not reproduce the square waveform.

Video amplifiers may be square wave tested in the same manner as described for testing audio amplifiers. The test frequencies might be 60 cps for the low end and 25,000 cps for the high frequency end.

**SERVICING TV RECEIVERS:** One major use of the scope in tv servicing is alignment in conjunction with a TV/FM Sweep Generator. First, the IF stages are aligned, and then the RF and local oscillator stages, following the general method and theory of alignment described in the sweep generator instruction manuals. The specific methods of alignment depend on the receiver, and the manufacturer's service instruction should always be followed.

Another major use of the 'scope is to check the waveform of the complex tv signal as it passes through the receiver. The exceptional fidelity of the 'scope is very important in this application, since you must be able to observe small variations in waveform in order to localize and correct the cause of poor picture quality. Here again, the set manufacturer provides representative waveforms to be expected at specific points in a specific model of receiver. These waveform pictures are furnished for the entire receiver, with the exception of the tuner portion.

Keep in mind that two basic frequencies are involved in checking waveform of signals in tv receivers. The vertical or field frequency is 60 cps. Any waveform check, except with the horizontal oscillator, its differentiator network, and the horizontal amplifier stages, can generally be made using an internal linear sweep frequency of 30 cycles to show two complete fields of the signal. To examine the horizontal pulse shape, or the operation of the horizontal deflection system, it is generally suitable to use an internal linear sweep frequency of 7875 cps, again to show two complete lines of the signal.

## SECTION IV. MAINTENANCE

### 4-1 GENERAL

Included in this section are instructions for trimmer capacitor C1 adjustment, trouble-shooting, and parts replacement.

### 4-2. REMOVAL FROM CABINET

To remove the instrument from the cabinet, first disconnect it from the power line and remove the two No. 8-32 x 3/8 machine screws in the cabinet rear. Then slide the chassis out the front of the cabinet.

#### WARNING

The voltages in this instrument are dangerous. Take caution to avoid personal contact with these voltages when the instrument is being operated outside of its cabinet. Remember that capacitors may remain charged to dangerously high voltages for a considerable time after power has been removed.

### 4-3. TRIMMER CAPACITOR C1 ADJUSTMENT

Connect a jumper from pin 2 of V5 and the VERT. INPUT terminal. Set the SYNC SELECTOR to INT., the SWEEP RANGE switch at the 1K-10K position, and the SWEEP VERNIER at MIN. Now set the VERT. ATTENUATOR at HI, and then use the panel controls to obtain a centered, focused trace entirely on the screen. With the trimmer C1 adjusted improperly, the trace will appear either as in Fig. 8a or Fig. 8b. If this is the case, adjust C1 (see Fig. 2) until the hook disappears and the trace is a straight line as in Fig. 8c. Be sure to use an insulated alignment tool.

A much preferred method of adjustment, when the equipment is available, is to apply a square wave of approximately 1kc fundamental frequency to the VERT. INPUT and ground terminals. With the VERT. ATTENUATOR set to HI, adjust trimmer C1 for the best possible square wave reproduction. Internal sweep is employed and the panel controls set for several stationary square waves on the screen before adjusting the trimmer for proper frequency compensation.

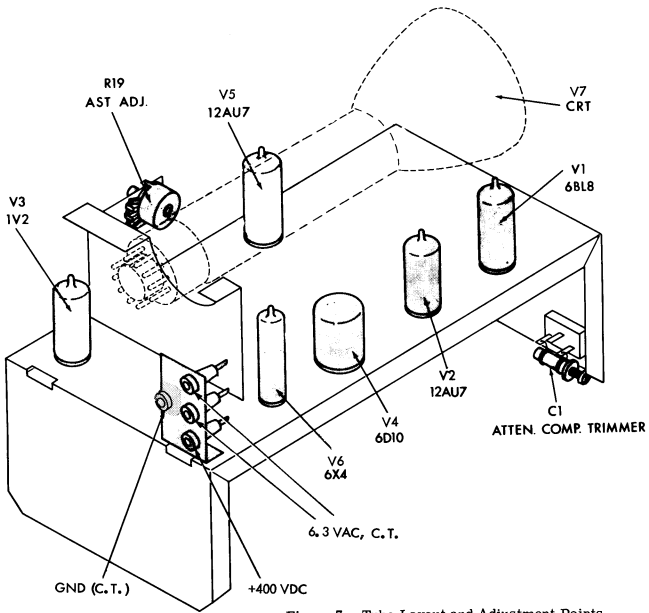


Figure 7. Tube Layout and Adjustment Points

Under-compensation and over-compensation are indicated by square waves appearing as in Figs. 9a and 9b, respectively. Proper compensation is indicated by square waves appearing as in Fig. 9c.



Figure 8. Trimmer Adjust Pattern



Figure 9. Trimmer Adjust Pattern



#### 4-4 TROUBLESHOOTING

As an aid in localizing trouble, common symptoms together with their possible causes and remedies have been listed in groups corresponding to the major sections of the instrument. Of course, all possible troubles could not be included in the chart and the make-up of the chart has been based on the assumption that the instrument has worked properly at some previous time. Keep in mind that in trouble-shooting, the main endeavor is to find and eliminate the source of the trouble. Recurrence of a trouble usually indicates that the effect, not the cause has been remedied.

#### 4-5 TUBE REPLACEMENT

Tube location is shown in Fig. 7. When the CRT is replaced, it must be rotated until the horizontal trace is level.

#### 4-6 FUSE REPLACEMENT

A 1 Amp fuse is located in the fuseholder on the rear chassis apron. If the fuse should blow, the component that has failed and caused the excessive current drain must be found and replaced before a new fuse is inserted.

#### 4-7. TROUBLESHOOTING CHART

<u>SYMPTOM</u>	<u>TROUBLE</u>	<u>REMEDY</u>
POWER SUPPLY		
Pilot light fails to light	INTENSITY switch in OFF position No AC line voltage Pilot lamp open Fuse defective Power transformer defective Broken lead/or leads in the filament path	Turn INTENSITY switch clockwise Trace line failure Replace I1 Replace F1 Replace T1 Repair defective connections
Fuse, F1, blows when AC power is turned on	Shorted AC line cable on the primary side of the power transformer Defective rectifier tubes Defective filter capacitors  Short in filament connections	Repair the short  Check V3, V6. Replace if bad. Check C13, C10, C11, for low resistance or short. Replace if necessary Check filament connections for shorts. Repair if necessary.
Some or all filaments fail to light	Defective tube or tubes Broken lead from power transformer  Power transformer defective	Replace tube or tubes* Check with an ohmmeter for continuity. Repair if necessary.  Replace

\*Indicates replacement of component in this group makes it necessary to repeat some part of the initial adjustment procedure.

### CRT CIRCUIT

No spot on CRT screen	<p>High voltage rectifier tube, V3, defective                      Filament leads broken                      No voltage on second anode</p> <p>Note: Spot may be deflected off screen. Adjust V-POS. control for equal voltages from CRT pins 6 &amp; 7 to ground (V. defl. plates) and H. POS. control for equal voltages from CRT pins 9 &amp; 10 to ground (H. defl. plates). The spot should then be centered. If either adjustment is impossible, refer to the vertical or horizontal amplifier sections.</p>	<p>Replace</p> <p>Repair                      Check circuit. Repair if necessary.</p>
No spot on CRT screen (All CRT voltages correct)	Defective CRT (V7)	Replace (V7)
Retrace blanking in-operative	<p>C12 open                      Broken lead from the sweep frequency generator to the cathode of V7</p>	<p>Replace                      Check if necessary</p>
No focusing	<p>R21 defective                      R19 defective</p> <p>Note: R21 is the focusing potentiometer. Its action is dependent on the setting of the astigmatism, potentiometer R19. For best focus, both pots must be adjusted simultaneously as an initial adjustment.</p>	<p>Replace                      Replace</p>
No horizontal positioning	Refer to horizontal amplifier	
No vertical positioning	Refer to vertical amplifier	
Astigmatism control in-operative	R19 defective	Replace

### SWEEP CIRCUIT

No sweep (hor. ampl. checks O. K.)	<p>Sweep Selector switch is not set to sweep positions                      Lead or leads broken                      V4 defective                      S3 defective                      R36 defective</p>	<p>Set Sweep Selector to any of the sweep positions                      Check and repair if necessary                      Replace                      Check. Replace if necessary                      Check. Replace if necessary</p>
------------------------------------	---	---

SWEEP CIRCUIT (Cont'd.)

Sweep inoperative on some ranges	One of C17-20 defective S3 defective	Replace the defective capacitor* Replace
Loss of synchronization	V4C defective S4 defective C14 open Sync leads defective	Replace V4 Check. Replace if necessary Replace Replace

VERTICAL AMPLIFIER

With appropriate signal applied to INPUT, no vertical displacement of the trace results.	Defective S1 One or more tubes defective One or more components in the vertical amplifier defective	Check. Replace if necessary Check V1. Replace if defective Check resistors and potentiometers with ohmmeter. Replace if defective
No vertical positioning	R12 defective	Replace R12
No vertical signal	C3 open Open leads	Replace C3 Repair
Square wave (1kc) distorted in HI POS. of the attenuator	C1 out of adjustment	Adjust C1
No vertical gain adjust	R8 defective	Replace R8
Trace "jumps" vertically on CRT screen	Loose connection in vertical amplifier section One of the tubes "microphonic" Line voltage variations	Repair  Tap tubes lightly. Replace the one which is "microphonic". Not scope defect

HORIZONTAL AMPLIFIER

No horizontal deflection; sweep checks O.K. and SWEEP SELECTOR in one of SWEEP positions	C7 open V5 defective C13 shorted S3 defective	Replace Check and replace if bad Replace Replace
No horizontal positioning	R43, R44, R45, R46, R47 defective	Check and replace if necessary
Horizontal deflection present but distorted	C13 open V5 defective R41, 42 defective C8, C9 open	Replace Replace Replace Replace
Trace off screen	C8, C9 shorted	Replace

## SECTION V. SERVICE POLICY

### SERVICE CONSULTATION

If you are experiencing trouble that you cannot diagnose yourself, you are invited to avail yourself of our Consultation Department. The consultant handling your inquiry will make every effort to diagnose the cause of your particular difficulty based on the information that you provide. Please be as thorough as possible. Include the following information about your unit:

- a) Have you made a thorough check of the wiring, checking also for cold solder joints, or accidental shorting between parts, or to chassis? (Check to see whether a bare wire or lead extends far enough to be shorted when the bottom plate is put on).
- b) Have you checked that the proper tube is in each socket, and also making proper contact in the socket?
- c) Does the trouble occur at one time or one operating situation, but not at another time or operating situation? Be as specific as possible in this respect.
- d) If the unit is of the type that involves alignment or calibration, be as specific as possible as to what you have done or not done with regard to these requirements.
- e) Have you observed any peculiarity about a part? If a part appears charred or otherwise damaged by excessive heat, please say so. If you think you have damaged a particular part in the assembly or wiring, please say so. In conjunction with the symptoms, the consultant may be able to determine whether such a part is likely to be defective.
- f) Have you gone through any trouble-shooting procedure that may be provided? If your manual includes a table of contacts made at each switch position, have you checked out the switches accordingly (if the trouble is such that doing this would be appropriate)? Have you been able to make checks of the operating voltage and/or resistances, if this is appropriate, and your manual provides a table of voltages and resistances? What are the results of these checks? Also, have you taken any other trouble-shooting approaches? What have been the results?

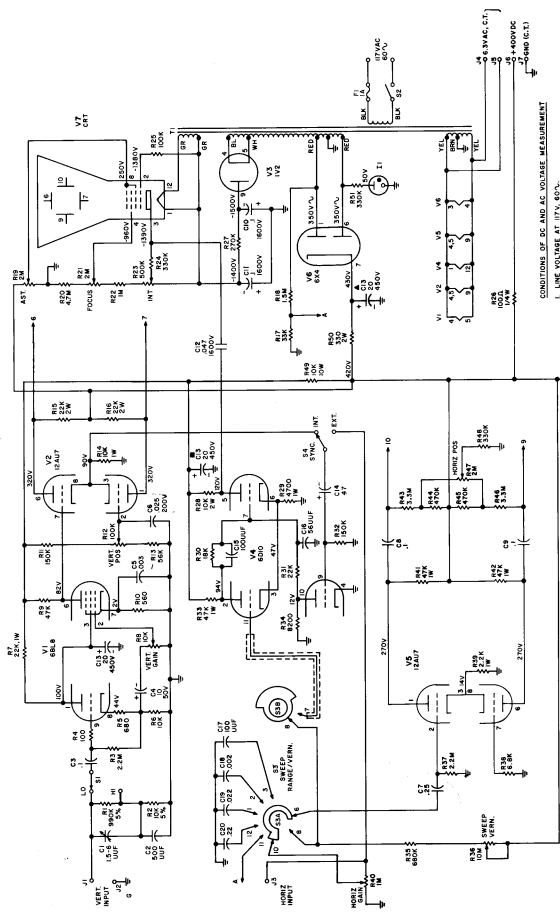
### PARTS REPLACEMENT

If it appears that a component is defective, and you desire a replacement, address your correspondence to our Technical Service Department.

Give stock number and description of part as given on the parts list.

Describe as completely as possible the nature of the defect, or your reason for requiring replacement.

**DO NOT RETURN ANY PART OR COMPLETE UNIT WITHOUT CORRESPONDING WITH US FIRST.**



- NOTES:
1. ALL RESISTANCE VALUES ARE IN OHMS
  2. OTHERWISE SPECIFIED
  3. ALL CAPACITANCE VALUES ARE IN UUF, (MICROFARAD) UNLESS OTHERWISE SPECIFIED.

- CONDITIONS OF DC AND AC VOLTAGE MEASUREMENT
1. LINE VOLTAGE AT 170V, 60V.
  2. INTENSITY AT MAX.
  3. SWEEP RANGE AT 100-HZ, POT VERNIER AT MIN.
  4. VERTICAL AND HORIZONTAL AMP GAIN AT MIN.
  5. VERTICAL ATTEN AT LO.
  6. VERTICAL AND HORIZONTAL AT THE CENTER.

**SCHEMATIC DIAGRAM**

## PARTS LIST

### MODEL 54-45 - PACKAGE #1 KIT

<u>STOCK#</u>	<u>DESCRIPTION</u>	<u>AM'T.</u>	<u>STOCK#</u>	<u>DESCRIPTION</u>	<u>AM'T.</u>
<u>A54-45-01 (#4 Envelope) - #4 Hardware</u>			<u>A54-45-06 (#4 Envelope)</u>		
40007	nut, hex, #4-40 x 1/4	12	54006	terminal strip, 3 post, 2 right	1
40034	nut, Tinnerman #4	4	54018	terminal strip, 4 post, w/gnd.	3
41090	screw, #4-40 x 5/16, B. H.	12	54076	terminal strip, 4 post, 3 rt. w/gnd.	1
41091	screw, #4-40 x 1/4, Fl. Hd.	4	91002	fuse, 1A	1
42007	washer, lock #4	12			
<u>A54-45-02 (#4 Envelope) - #6 Hardware</u>			<u>A54-45-07 (Bag)</u>		
40000	nut, hex, #6-32 x 1/4	21	62017	switch, slide SPDT 29/64, white	2
40019	nut, Tinnerman, #6-32	2	97022	socket, 7 pin	1
41007	screw, #6-32 x 3/4, B. H.	2	97025	socket, 9 pin	4
41015	screw, #6-32 x 3/8, Fl. Hd.	4	97026	socket, CRT 12 Pin wafer	1
41063	screw, #6-32 x 1/4, F. H. M.	2	97064	socket, 12 pin Compactron	1
41086	screw, #6-32 x 5/16, B. H.	16	97805	fuseholder, short type, black	1
41140	screw, #6-32 x 1/4 - Type F self threading Rd. Hd. Ph.	10			
42002	washer, lock #6	19	<u>B54-45-01 (Box)</u>		
43000	lug, ground #6	1	58004	wire, hook-up, (Black - 2 ft.)	1
	washer, flat #6	2	58005	wire, hook-up, (Brown - 2 ft.)	1
<u>A54-45-03 (#4 Envelope) - #8 Hardware</u>			58006	wire, hook-up, (Red - 2-1/2 ft.)	1
40017	nut, Tinnerman #8-32	2	58007	wire, hook-up, (Orange - 3 ft.)	1
40045	nut, hex, #8-32 x 5/16	10	58008	wire, hook-up, (Yellow - 2 ft.)	1
41003	screw, #8-32 x 3/8, B. H.	6	58009	wire, hook-up, (Green - 1-1/2 ft.)	1
42008	washer, lock #8	4			
43004	lug, solder #8	3	58010	wire, hook-up, (Blue - 1-1/2 ft.)	1
<u>A54-45-04 (#4 Envelope) - Misc. Hardware</u>					
40001	nut, hex, 3/8-32 x 1/2	7	58011	wire, hook-up, (Violet - 1 ft.)	1
40016	nut, hex, 1/2-24	1	58012	wire, hook-up, (Gray - 2 ft.)	1
42001	washer, flat, 3/8	7	58034	wire, hook-up, (Black - 2 ft.)	1
42029	washer, rubber, 1/2 I. D.	1	58036	wire, hook-up, (White w/black tracer - 2 ft.)	1
42511	retainer ring,	5	58043	wire, hook-up, (Black - 1/2 ft.)	1
43001	lug, pot ground, 3/8	2	58044	wire, hook-up, (Brown - 4 ft.)	1
46001	grommet, rubber 1/4"	5	58045	wire, hook-up, (Red - 1 ft.)	1
46014	grommet, rubber 1/8"	7	58046	wire, hook-up, (Orange - 2 ft.)	1
46018	grommet, rubber 1"	1	58047	wire, hook-up, (Yellow - 1-1/2 ft.)	1
82101	strain relief	1	58048	wire, hook-up, (Green - 3 ft.)	1
<u>A54-45-05 (#4 Envelope)</u>			58049	wire, hook-up, (Blue - 2-1/2 ft.)	1
54002	terminal strip, 1 post, rt. w/gnd.	1			
54004	terminal strip, 2 post, w/gnd.	3	58050	wire, hook-up, (Violet - 2 ft.)	1
54013	terminal strip, 1 post, lt. w/gnd.	1	58051	wire, hook-up, (Gray - 2 ft.)	1
54014	terminal strip, 3 post, 2 left	1	58052	wire, hook-up, (White - 1/2 ft.)	1
54023	terminal strip, 2 post, lt. w/gnd.	1	58300	spaghetti (tubing) 1 ft.	1
54024	terminal strip, 2 post, left	1	58416	cable, RG174/U (Black - 2-1/2 ft.)	1
			58501	wire, bare, #22 (1 ft.)	1
			57004	line cord	1

MODEL 54-45 - PACKAGE #3 KIT

<u>STOCK#</u>	<u>DESCRIPTION</u>	<u>AM'T.</u>	<u>STOCK#</u>	<u>DESCRIPTION</u>	<u>AM'T.</u>
<u>A54-45-10 (#4 Envelope)</u>					
			10107	res., car., 100Ω, 1/4W, 10%	1
			10406	res., car., 680Ω, 1/2W, 10%	1
			10408	res., car., 680K, 1/2W, 10%	1
			10412	res., car., 330K, 1/2W, 10%	3
			10421	res., car., 6.8K, 1/2W, 10%	1
			10424	res., car., 22K, 1/2W, 10%	1
			11577	res., car., dep., 990K, 1/2W, 5%	1
			22509	cap., disc, 100pf, 500V, 10%	1
66401	Oscilloscope Manual #54-45	1	<u>A54-45-11 (#4 Envelope)</u>		
81477	chassis	1	10433	res., car., 560Ω, 1/2W, 10%	1
<u>MODEL 54-45 - PACKAGE #2 KIT</u>					
<u>STOCK#</u>	<u>DESCRIPTION</u>	<u>AM'T.</u>	10452	res., car., 8.2K, 1/2W, 10%	1
<u>A54-45-08 (#4 Envelope)</u>					
42060	platform, plastic	5	10849	res., 47K, 1W, 10%	3
42061	washer, flat, special #8	3	10851	res., 22K, 1W, 10%	1
42062	washer, split, #8	3	10853	res., 10K, 1W, 10%	1
50028	jack, pin, molded, red	1	10855	res., 4.7K, 1W, 10%	1
50029	jack, pin, molded, black	3	10857	res., 2.2K, 1W, 10%	1
97715	pilot light assembly, neon snap-on, white	1	11500	res., car., dep., 10K, 1/2W, 5%	1
<u>A54-45-09 (Bag)</u>					
16006	pot., St. car., 20% linear, 1MΩ	1	22549	cap., disc, .003mfd 500V, 10%	1
16011	pot., St. car., 20% linear, 2MΩ	2	<u>A54-45-12 (#4 Envelope)</u>		
18107	pot., 10K linear, 20%	1	10431	res., car., 470K, 1/2W, 10%	2
18108	pot., 100K, linear, 20%	1	10434	res., car., 2.2M, 1/2W, 10%	2
18110	pot., 500K, linear, 20% SPST	1	10439	res., car., 100Ω, 1/2W, 10%	1
52007	binding post, #8, shaft	3	10453	res., car., 18K, 1/2W, 10%	1
<u>B54-45-02 (Carton)</u>					
60120	switch, rot., w/10M pot.	1	10457	res., car., 3.3M, 1/2W, 10%	2
			22515	cap., disc, 500pf, 500V, 10%	1
			22546	cap., disc, 56pf, 500V, 10%	1
			10400	res., car., 10K, 1/2W, 10%	1
80185	front panel	1	<u>A54-45-13 (#4 Envelope)</u>		
81362	bezel, plastic	1	10962	res., car., 22K, 2W, 10%	2
86011	frame	1	20062	cap., mylar, .025mfd, 200V, 10%	1
			20070	cap., mylar, .022mfd, 200V, 10%	1
			23065	cap., elec., 10mfd, 50V	1
			29513	cap., var., tub., 1.5-6pf, 1000V	1
			<u>A54-45-14 (#4 Envelope)</u>		
			20015	cap., mylar, .25mfd, 600V, 20%	1
			20057	cap., mylar, .47mfd, 200V, 20%	1
			20089	cap., mylar, .1mfd, 400V, 10%	1
			20098	cap., mylar, .1mfd, 600V, 20%	1

MODEL 54-45 - PACKAGE #5 KIT

STOCK#	DESCRIPTION	AM'T.	STOCK#	DESCRIPTION	AM'T.
<u>A54-45-18 (#4 Envelope)</u>					
	10418 res., car., 4.7M, 1/2W, 10%	1			
	10407 res., car., 1M, 1/2W, 10%	1			
	10410 res., car., 100K, 1/2W, 10%	1			
	10425 res., car., 56K, 1/2W, 10%	1			
	22509 cap., disc., 100pf, 500V, 10%	1			
	22595 cap., disc., 2000pf, 500V, 10%	1			

30043 transformer, power 1

MODEL 54-45 - PACKAGE #4 KIT

STOCK#	DESCRIPTION	AM'T.
<u>A54-45-15 (#4 Envelope)</u>		
10419 res., car., 270K, 1/2W, 10%		1
10428 res., car., 47K, 1/2W, 10%		1
10426 res., car., 33K, 1/2W, 10%		1
10435 res., car., 150K, 1/2W, 10%		2
10455 res., car., 1.5M, 1/2W, 10%		1

A54-45-16 (#4 Envelope)

10956 res., car., 10K, 2W, 10%	1
10970 res., car., 330Ω, 2W, 10%	1
20085 cap., mylar, .22mfd, 200V, 10%	1
20089 cap., mylar, .1mfd, 400V, 10%	1

A54-45-17 (Bag)

14300 res., w.w. 10K, 10W, 10%	1
18017 pot., spec., white, 2MΩ, snap-in, linear	1
20090 cap., mylar, .1mfd, 1600V, 10%	2
20096 cap., mylar, .047mfd, 1600V, 10%	1

24012 cap., elect., 1 x 40, 3 x 20mfd, 450V	1
81364 chassis, rear	1
81476 bracket, jacks "Power"	1
81914 bracket, pot	1
90036 tube, 6X4	1

A54-45-21 (#5-1/2 Envelope)

59005 screen	1
59006 filter, green	1
89353 label	1

MODEL 54-45 - PACKAGE #6 KIT

STOCK#	DESCRIPTION	AM'T.
<u>A54-45-19 (#4 Envelope)</u>		
46016 foot, plastic		4
59308 felt cushion, CRT		4

A54-45-20 (Bag)

53036 knob, 1-1/16 dia.	2
53037 knob, 3/4 dia.	4
53040 knob, concentric, outer	1
53041 knob, concentric, inner	1
59304 strip, rubber	1
89649 handle mounting bracket	2

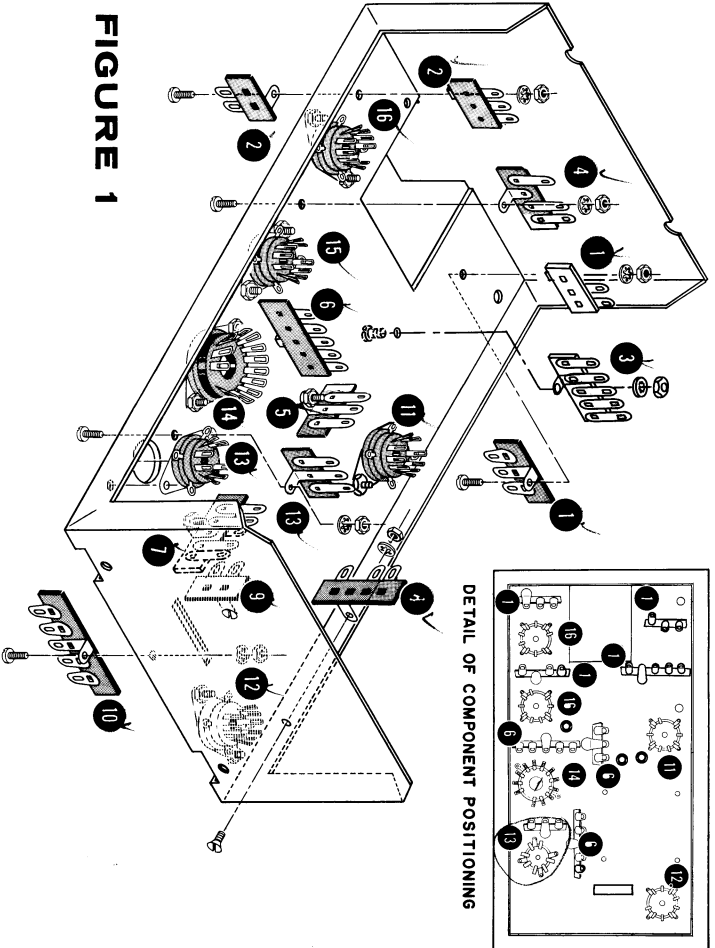
B54-45-04 (Box)

81363 CRT Clamp	2
87006 handle w/links	1
90030 tube, IV2	1
90033 tube, 12AU7	2
90071 tube, 6BL8	1
90081 tube, 6D10	1

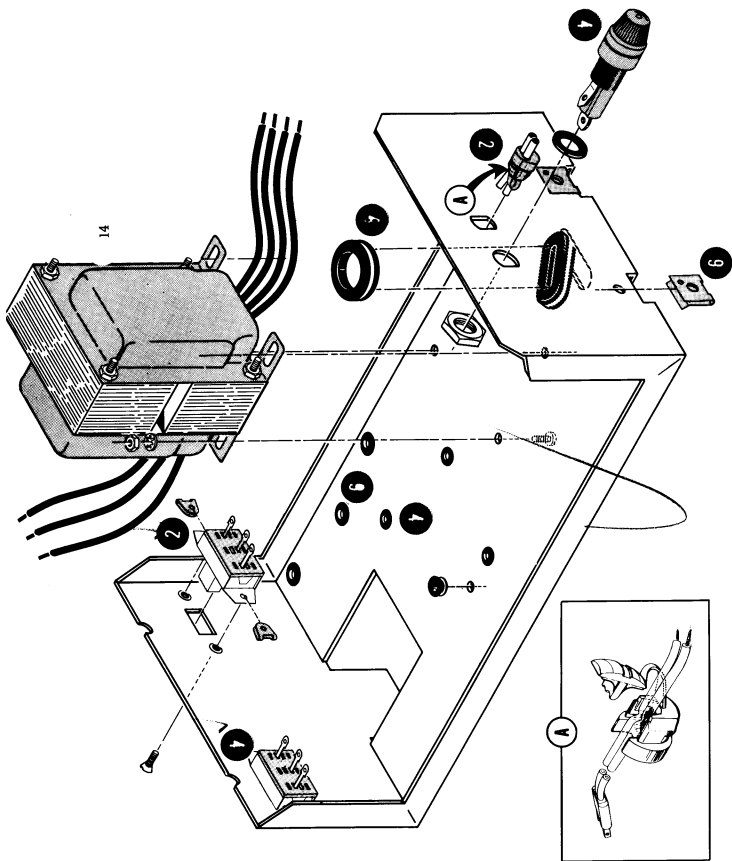
88140 cabinet	1
90108 tube, CRT, WX5078P1	1





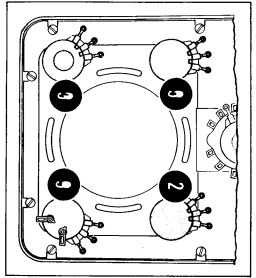
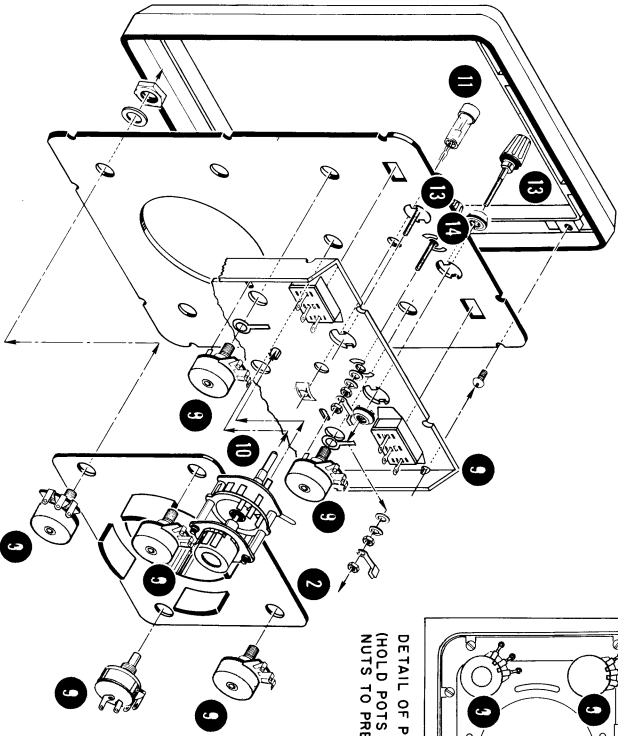


**FIGURE 1**



**FIGURE 2**

**FIGURE 3**



**DETAIL OF POT LUG POSITIONING  
(HOLD POTS WHEN TIGHTENING  
NUTS TO PREVENT ROTATION)**

FIGURE 2

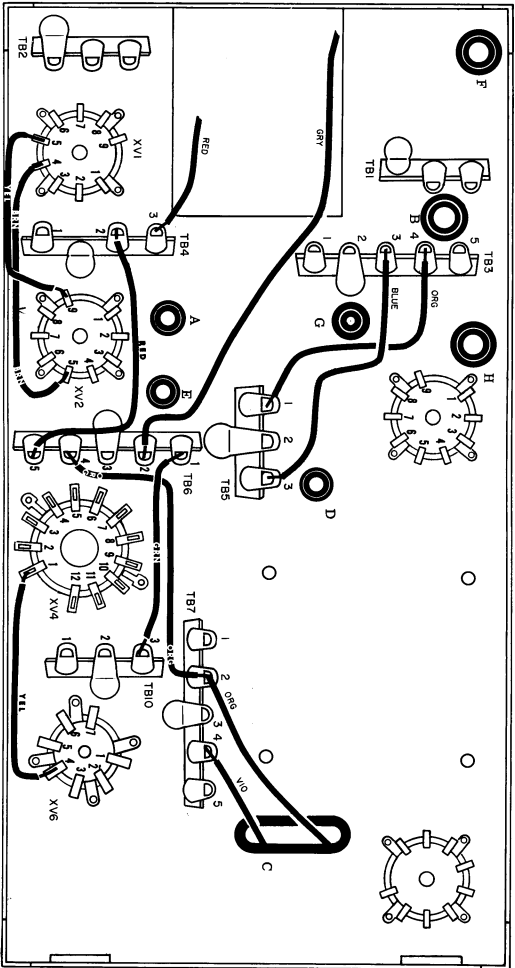
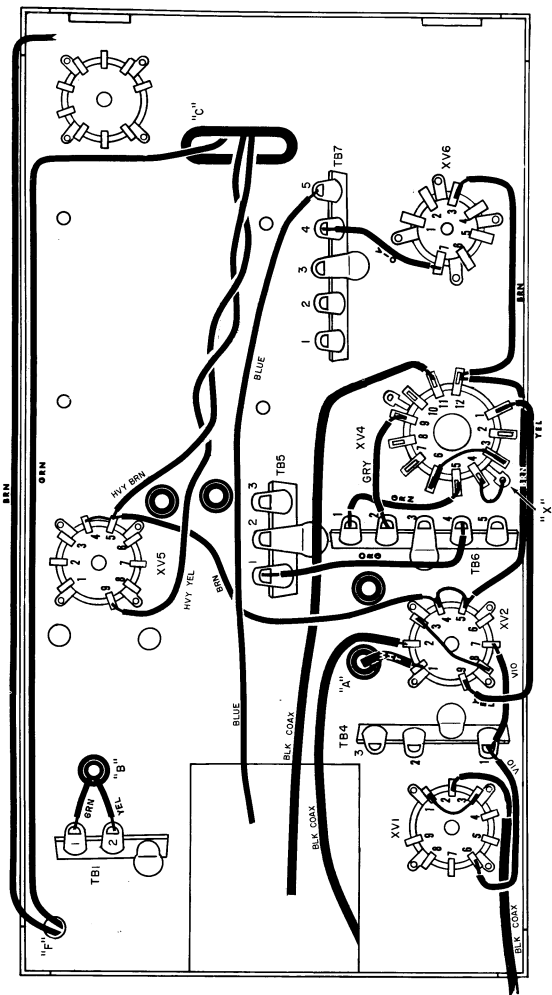
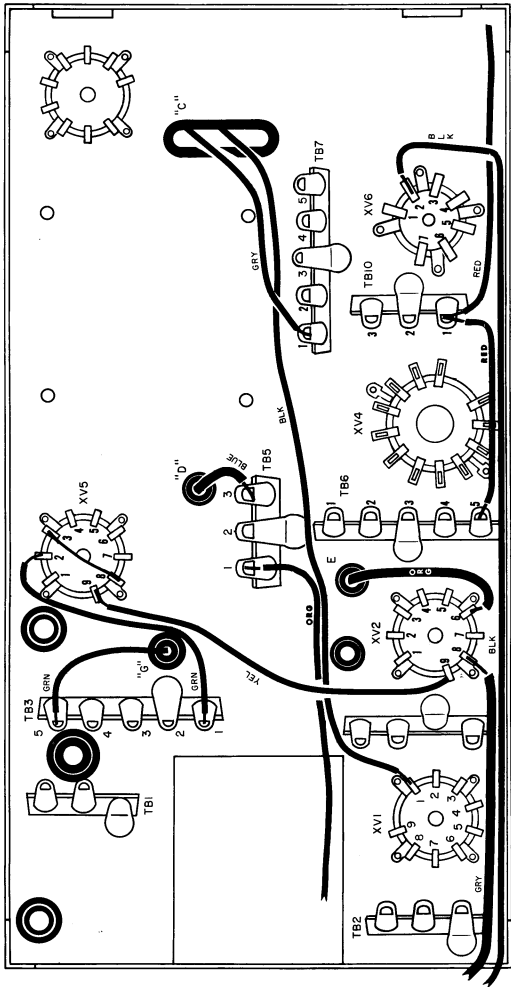


FIGURE 4



**FIGURE 5**





**FIGURE 6**

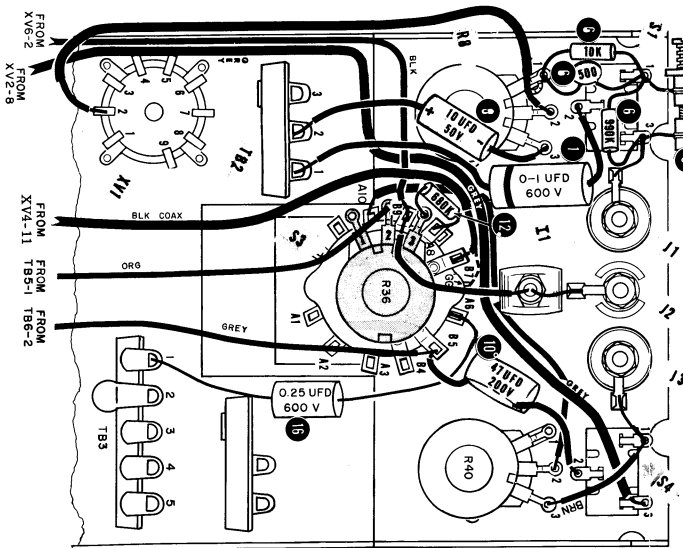
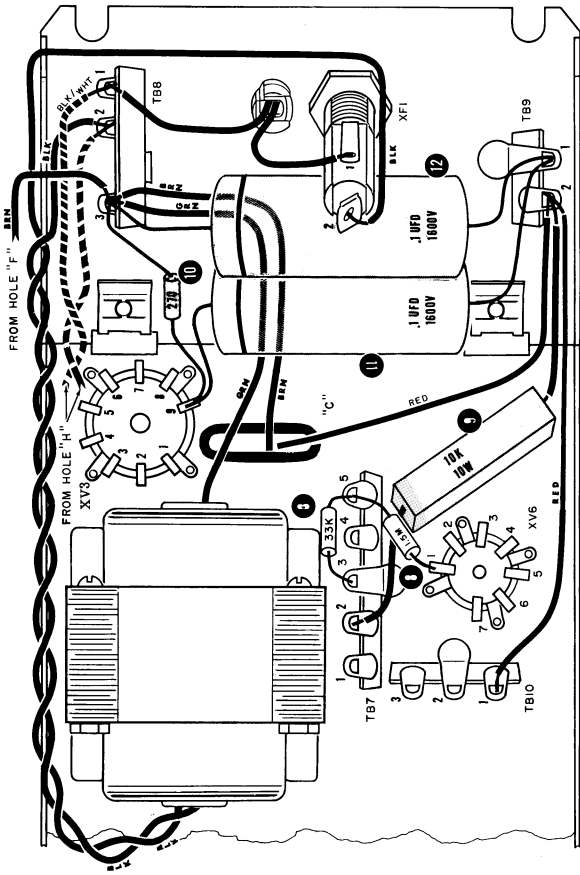


FIGURE 7

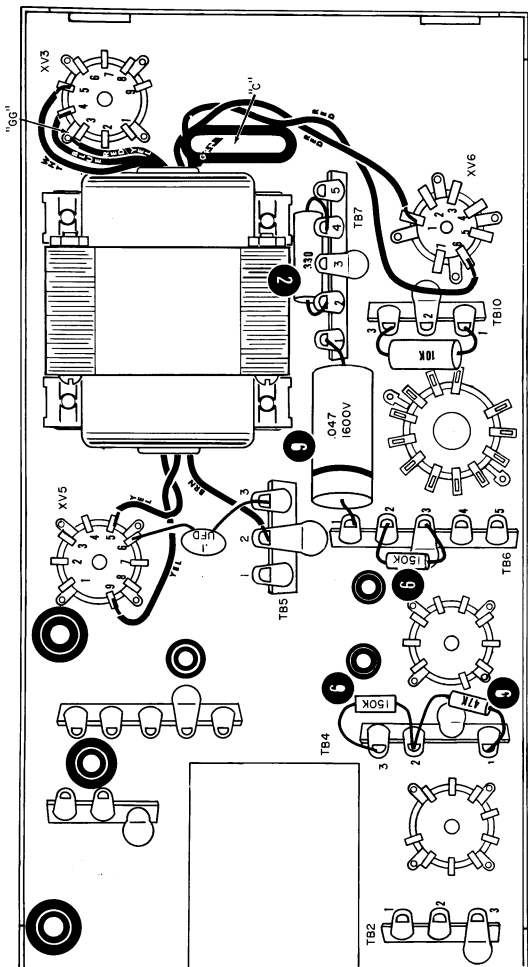






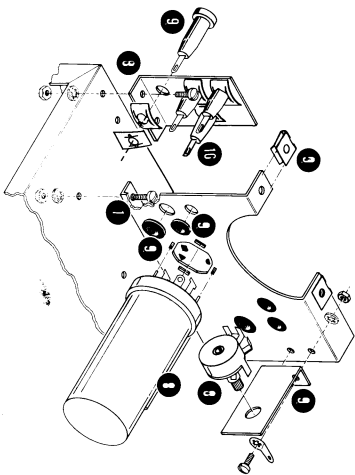


**FIGURE 9**



**FIGURE 10**

**FIGURE 11**



**FIGURE**

